

HBA

Industrial dehumidifiers



HBA (A)



HBA (P)



HBA dehumidifiers series are high-performances units especially designed for industrial or commercial purposes where humidity level should be controlled or water vapor condensation should be prevented. These units are particularly indicated for archives, ironing rooms, bookstores, cheese factories, underground rooms, cellars and industrial sites where high humidity level is present. This series comprises 5 models which cover a capacity range from 50 to 200 l/24h. HBA units are designed for easy maintenance and service, each part being readily accessible and, when required, easily replaceable thus reducing service and maintenance costs.

HBA units are designed for easy maintenance and service, each part being readily accessible and, when required, easily replaceable thus reducing service and maintenance costs.

The units are supplied with a solenoid valves set for the hot gas injection used to defrost the evaporator in case of severe working conditions.

Versions

- A Version with cabinet
- P Ductable units.

HBA/A-P		50	75	100	150	200
Moisture removed at 30°C - 80%	l/24h	49,0	73,0	95,0	155,0	190,0
Moisture removed at 30°C - 60%	l/24h	40,1	56,6	77,3	113,1	143,5
Moisture removed at 27°C - 60%	l/24h	35,6	50,7	68,9	96,6	131,7
Moisture removed at 20°C - 60%	l/24h	25,8	35,6	51,3	71,5	96,6
Nominal input power	kW	0,9	1,2	1,6	1,9	2,5
Maximum input power	kW	1,2	1,5	2,0	2,3	3,1
Maximum input current ⁽¹⁾	A	3,9	5,6	8,4	10,5	13,2
Peak current	A	19,1	20,1	38,4	44,7	63,7
Air Flow	m ³ /h	500	800	1000	1400	1650
Available static pressure	Pa	40	40	40	40	40
Refrigerant		R410A	R410A	R410A	R410A	R410A
Global warming potential (GWP)		2088	2088	2088	2088	2088
Refrigerant charge	Kg	0,47	0,60	0,70	1,20	1,20
Equivalent CO ₂ charge	t	0,98	1,25	1,46	2,51	2,51
Sound power ⁽³⁾	dB(A)	54	57	57	59	61
Sound pressure ⁽⁴⁾	dB(A)	47	50	50	52	54
Power supply	V/Ph/Hz	230/1/50	230/1/50	230/1/50	230/1/50	230/1/50

Performances are referred to the following conditions:

(1) Temperature 30°C; Humidity 80%

(2) Room temperature 30°C; water temperature 80/70°C, at compressor OFF

(3) Sound power level calculated according to ISO 9614.

(4) Sound pressure level measured at 1 mt from the unit in free field conditions according to ISO 9614.

Operation limits

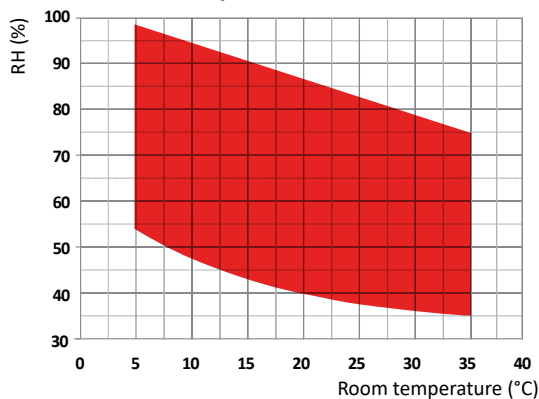

Standard version (A)

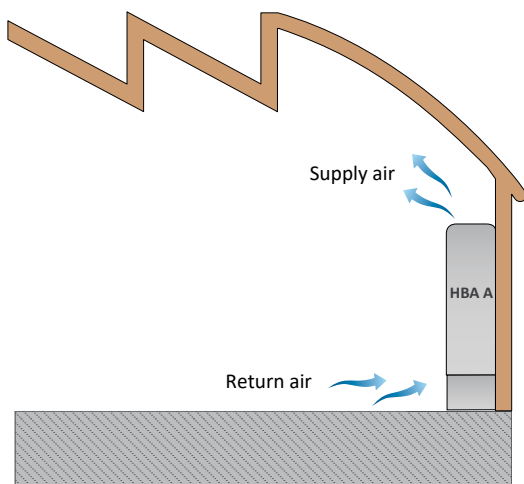

Ducted version (P)

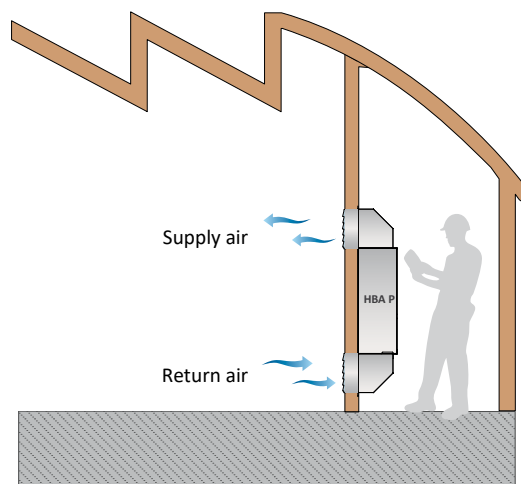

Frame

All units are made from hot-galvanised thick sheet metal, painted with polyurethane powder enamel at 180°C to ensure the best resistance against the atmospheric agents and to operate in aggressive environments. The frame is self-supporting with removable panels. The colour of the unit is RAL 9010 both for the base and for the frontal panel.

Refrigerant circuit

The refrigerant gas used in these units is R410A. The refrigerant circuit is made by using international primary brands components and according to ISO 97/23 concerning welding procedures. The refrigerant circuit includes: sight glass, filter drier, thermal expansion valve with external equalizer, Schrader valves for maintenance and control, pressure safety device (according to PED regulation). All the units are supplied with injection valves kit for hot gas defrost cycle.

Compressor

The compressors are rotative type, with thermal overload protection by a klixon embedded in the motor winding. The compressor is mounted on rubber vibration dampers and it is supplied, standard, with sound-proof cover to reduce noise emission. The inspection is possible through the frontal panel of the unit that allows the maintenance of the compressor.

Condenser and evaporator

Condensers and evaporators are made of copper pipes and aluminium fins.

All evaporators are painted with epoxy powders to prevent corrosion problem due to their use in aggressive environments. The diameter of the copper pipes is 3/8" and the thickness of the aluminium fins is 0,1 mm. The tubes are mechanically expanded into the aluminium fins to improve the heat exchange factor. The geometry of these heat exchangers guarantees a low air side pressure drop and then the use of low rotation (and low noise emission) fans.

All units are supplied, standard, with a powder coated steel drip tray and all evaporators are supplied with a temperature sensor used as automatic defrost probe.

Fan

The fans are made of galvanized steel, centrifugal type. It is statically and dynamically balanced and supplied.

The electric motors are directly connected to the fan; they are all at 3 speeds, with integrated thermal protection. The protection class of the motors is IP 54.

Air filter

It is made of synthetic filtering media, ondulated type, without electro-static charge; they are all removable for differential disposal. Efficiency class G2, according to EN 779:2002.

Microprocessor

All units are supplied standard with microprocessor controls. The microprocessor controls the following functions: compressor timing, automatic defrost cycles, alarms.

An appropriate LCD display shows the operation mode of the unit, set point and alarms.

Electric box

The electric switch board is made according to electromagnetic compatibility norms CEE 73/23 and 89/336. The accessibility to the board is possible after removing the front panel of the unit and the OFF positioning of the main switch. If the unit is endowed of cabinet, after its removal.

Control and protection devices

All units are supplied with the following control and protection devices: antifreeze protection sensor, high pressure switch with manual reset, low pressure switch with automatic reset, high pressure safety valve, compressor thermal overload protection, fans thermal overload protection.

Test

All the units are fully assembled and wired at the factory, carefully evacuated and dried after leak tests under pressure and then charged with refrigerant R410A.

They are all fully operational tested before shipment. They all conform to European Directives and are individually marked with the CE label and provided with Conformity Declaration.

Accessories

HYGR - Remote mechanical hygrostat

To be installed on the wall, it is supplied with a regulation knob and working range from 30% to 100% with precision of 3%.

INSE - Serial interface card RS485

This interface card enables the controller to communicate with other devices using Modbus protocol.

PCRL - Remote control panel

This panel can be mounted up to 50m (maximum) from the unit and replicates all of the control functions. It is connected using a twin cable of 0.5 mm sq section.

RGDD - Humidity and Temperature electronic probe sensor

Built-in Electronic temperature and humidity probe.

KGBH - Louver kit and case for ducted version

Air grille double row adjustable brushed aluminium fins, equipped for wall mounting with subframe.

LS00 - Low noise version

This version includes the complete acoustic insulation of the unit (compressor + heat exchangers vanes) with compressor jackets and insulating material made with high density media and the interposition of heavy bitumen layer.

PMBH - Delivery and return plenum 90° (2 pieces)

To be used for "P" version to direct inlet/outlet air from/to swimming pool and vice versa. Galvanized steel made, coated with polyurethane powder to grant best resistance to weathering and operation in harsh environments.

ZOCC- Feet

Metallic galvanized steel feet, painted, used to install the unit on unsuitable walls. The feet can not be used in case the supply and return plenums are present.

HBA		50/A	50/P	75/A	75/P	100/A	100/P	150/A	150/P	200/A	200/P
A.C. fans ≤ 40 Pa		●	●	●	●	●	●	●	●	●	●
Hot gas defrost		●	●	●	●	●	●	●	●	●	●
Thermostatic valve		●	●	●	●	●	●	●	●	●	●
Low noise version	LS00	●	●	●	●	●	●	●	●	●	●
Main switch		●	●	●	●	●	●	●	●	●	●
Remote mechanical hygrostat	HYGR	○	○	○	○	○	○	○	○	○	○
Humidity and Temperature electronic probe sensor	RGDD	○	○	○	○	○	○	○	○	○	○
Remote control Panel	PCRL	○	○	○	○	○	○	○	○	○	○
Serial interface card RS485	INSE	○	○	○	○	○	○	○	○	○	○
Delivery and return plenum 90° (2 pieces)	PMBH	○	○	○	○	○	○	○	○	○	○
Feet	ZOCC	○	○	○	○	○	○	○	○	○	○
Louver kit and case for ducted version	KGBH	○	○	○	○	○	○	○	○	○	○

● Standard, ○ Optional, – Not available.

HBA - A

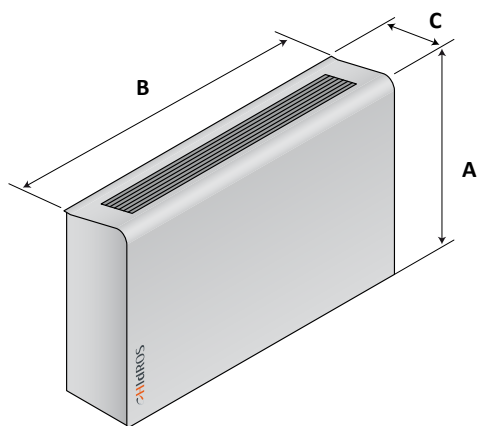

Mod.	A (mm)	B (mm)	C (mm)	Kg
50	750	760	260	50
75	750	1060	260	64
100	750	1060	260	68
150	836	1310	310	99
200	836	1310	310	102

HBA - P

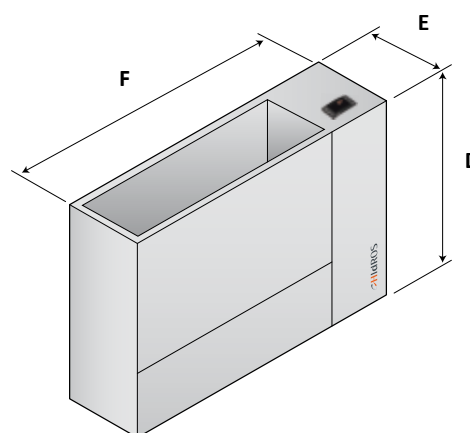

Mod.	D (mm)	E (mm)	F (mm)	Kg
50	680	250	706	41
75	680	250	1006	57
100	680	250	1006	61
150	770	300	1255	82
200	770	300	1255	87