

PARAGON Wall

Compact comfort module for offices



QUICK FACTS

- Ventilation, cooling and heating (water or electricity)
- Constant flow product with adjuster knob for quick and easy regulation of a constant air flow from the slot openings
- Designed for installation in the rear edge of the room and ideally is positioned above the adjacent corridor's suspended ceiling
- The product can also be integrated in the WISE system as a constant flow module with control of water valves
- Straightforward installation with two optional water connection sides and centred air connection
- One grille for both the supply air and the recirculated air
- Also available with optional factory-fitted control equipment
- Adjustable air direction ADC and adjustable grille louvres
- Low installation height
- High capacity

KEY FIGURES

Air flow range:		Pressure range:	Cooling capacity total:	Heating capacity: (W)	
l/s	m ³ /h	Pa	W	Water	Electricity
0 - 85	0 - 306	20 - 200	Up to 2682	Up to 4274	1000

SIZE

Length (mm)	Depth (mm)	Height (mm)
800, 1100, 1400	722 (+0-20)	286

Content

Technical description	3
PARAGON Wall.....	3
PARAGON Wall in brief.....	3
Basic function diagram.....	4
Air distribution.....	5
Control equipment.....	6
Different types of control equipment	7
Technical data.....	8
Sizing	9
K-factor setting.....	10
Installation	11
Suspension	11
Air connection	11
Connection - Water	12
Connection sizes.....	12
Accessories, control	14
Optional factory-fitted accessories	14
Accessories, factory-fitted.....	15
Loose accessories	17
Accessory kits.....	20
Specification.....	23
Specification, PARAGON Wall	23
Delivery demarcation PARAGON Wall	23
Factory-fitted optional extras	23
Available to order, kit and accessories	24
Ordering Key, Accessories	24
Ordering examples.....	25
Specification text.....	25

Technical description

PARAGON Wall

The product has been developed for creating a well-performing indoor climate in offices where technical installations are meant to be located in the rear edge of the room.

Strong focus has been directed on a high degree of comfort, low installation costs as well as low running costs in this application. Since the Paragon Wall is driven by a central air handling unit, there is no built-in fan that would otherwise generate sound and require servicing. Through patent-pending technology, the built-in coil is optimally utilised which provides high heating capacity already while the air pressure and air flows are low.

As the product uses the same grille for both the distribution of supplied air and the recirculation of the supply air, this makes a technical installation outside the relevant room possible, which gives several important advantages.

The product is primarily designed for offices with adjoining corridors. By utilising the space above the false ceiling in the adjoining corridor, service can be carried out in the corridor without the need for access to the room served by the unit. With only one grille to take into consideration, only one opening needs to be cut in the wall.

The product is also equipped with VariFlow and ADC for simple adjustment of the air flow and direction of air discharge. Vertical air discharge direction can also be set simply by adjusting the angle of the louvres in the grille.

PARAGON Wall in brief

- Optional factory fitted control equipment
- Low flow-generated noise level
- Draught-free indoor climate
- Straightforward installation with two optional water connection sides and centred air connection
- No fan in the room
- Dry system without condensation
- No need for any drainage system
- No filter
- Requires minimal maintenance
- Low energy consumption
- Guaranteed comfort through flexible adjustment of the direction of air discharge (ADC)
- Can ordered with or without grille.
- Upgradable to VAV and DCV

Design

PARAGON Wall is available in the following variants:

- Variant A: Ventilation, waterborne cooling.
- Variant B: Ventilation, waterborne cooling and heating.
- Variant X: Ventilation, waterborne cooling and electric heating.



Figure 1. PARAGON, front view



Figure 2. PARAGON, rear view



www.eurovent-certification.com
www.certiflash.com

Sizes and variants

The product is available in three different lengths 800, 1100 and 1400 mm.

All sizes can be ordered with the water connection on the left or right short side.

Basic function diagram

The primary air is supplied via duct connection in the rear edge of the unit and this builds up positive pressure inside the unit. The positive pressure distributes the primary air with relatively high velocity via the slot openings. The high velocity of the primary air creates negative pressure which generates induction of the room air.

The recirculation air is sucked into the unit through the same grille that is used for distributing air into the room.

The recirculation air is then conveyed through the coil where it is cooled, heated, if required, or just passes untreated, before it mixes with the primary air and is discharged into the room.

The air is ideally distributed to office rooms by discharging it in a fan shape and utilising as much of the ceiling and any intermediate walls as possible for preventing draughts in the occupied zone.

Horizontal air distribution is achieved by means of the ADC (Anti-Draught Control) feature. If vertical air distribution is desirable, this is achieved by setting the outlet grille vanes to slant upward or downward.

Our new generation PARAGON Wall has variable k-factor setting and large air flow range.

The product is a CAV product with fixed k-factor that is easy to upgrade to a VAV product with the help of an accessory kit. The product is also available as a complete VAV and DCV product, (see PARAGON Wall VAV and WISE Paragon Wall).

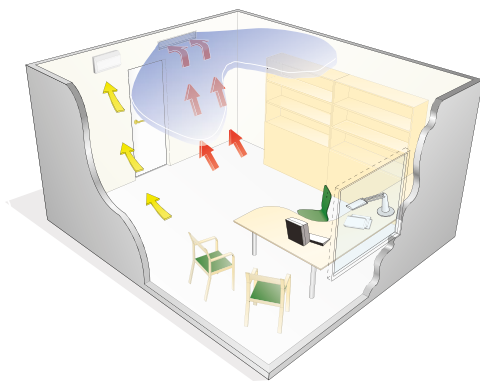

Figure 3. Air distribution with the Paragon Wall in a separate office room

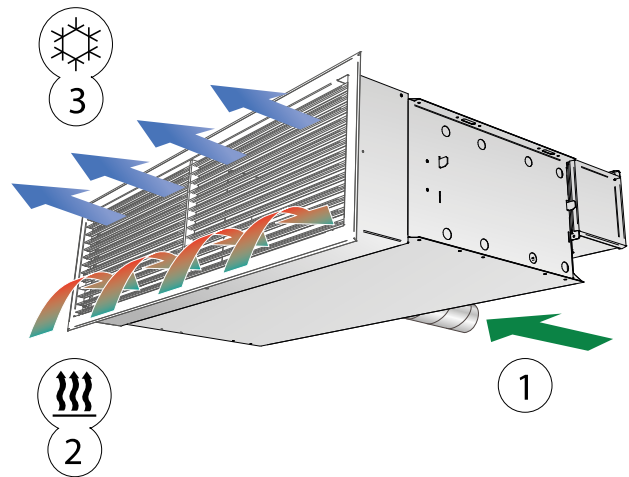

Figure 5 – Cooling function

- 1 = Primary air
- 2 = Induced room air
- 3 = Primary air mixed with chilled room air

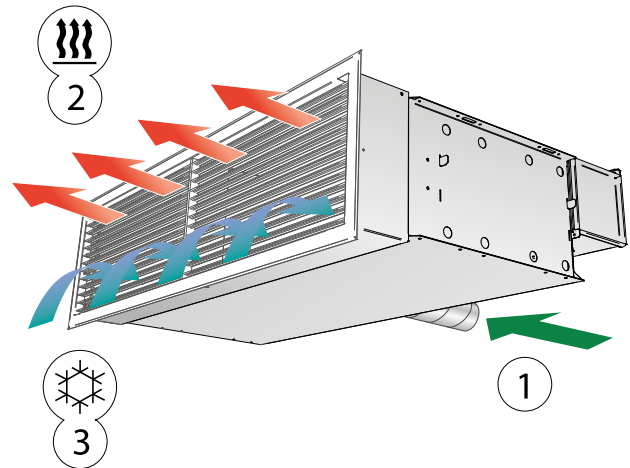

Figure 6 – Heating function (waterborne) also includes cooling function

- 1 = Primary air
- 2 = Primary air mixed with heated room air
- 3 = Induced room air

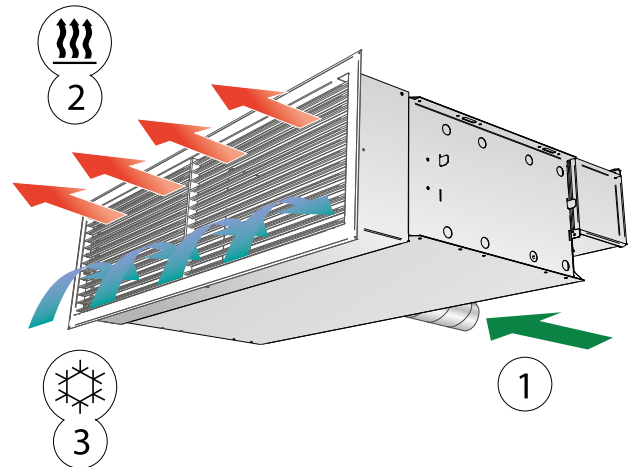

Figure 7 – Heating function (electricity) also includes cooling function

- 1 = Primary air
- 2 = Primary air mixed with heated room air
- 3 = Induced room air

Air distribution

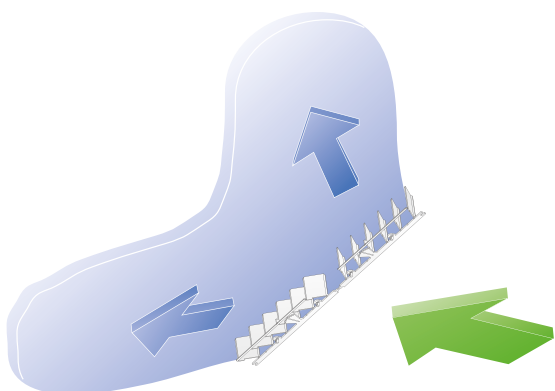

Figure 8 – Horizontal air distribution with ADC

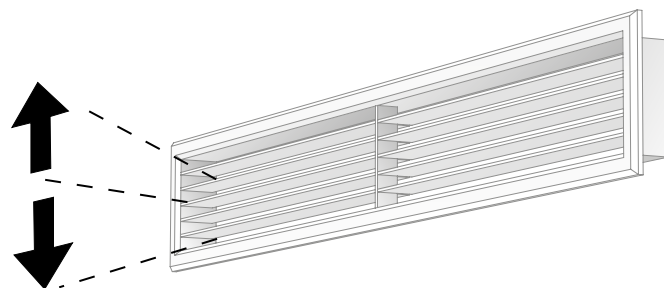

Figure 10. Vertical air distribution with adjustable louvers in the supply/return air grille.

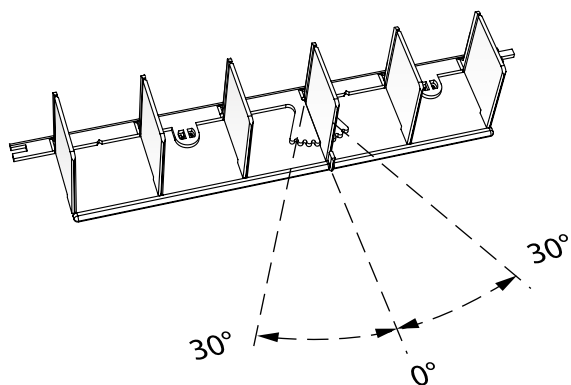

Figure 9. PARAGON ADC

Control equipment

PARAGON Wall is available with different control options that can be adapted to the true requirement in the office during the day.

PARAGON Wall is a constant flow product that in the standard design has a setting knob for easy and fast regulation of a constant air flow from the slot openings.

The product can also be integrated in the WISE system as a constant flow module with control of the water valves.

As standard, the product has a setting knob and two optional water connection sides and is also available with optional factory-fitted control equipment.

Factory-fitted optional extras

Factory-fitted control equipment makes the installation work simple. All components are accessible from the back of the product.

A selection of our optional factory-fitted extras:

Terminal block is included when a factory-fitted accessory is installed

Module Controller	Wiring terminal
Valve cooling	VDN215 Straight valve
Valve heating	VDN215 Straight valve
Actuator cooling	24V NC
Actuator heating	24V NC
Condensation sensor	CG IV
	WCD2

Read more about our factory-fitted options, kits and loose accessories in the "Accessories" section.

Also see the product sheet PARAGON Wall VAV and WISE PARAGON Wall on our website www.swegon.com.



Figure 11. PARAGON with water connection on the right-hand side.

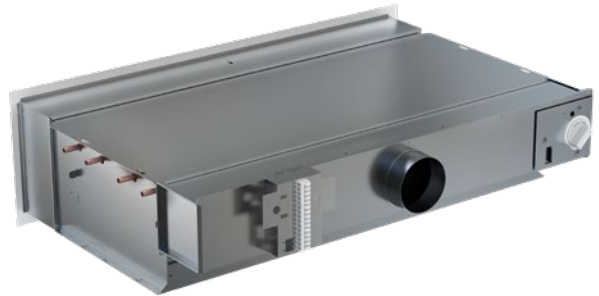

Figure 12. PARAGON with water connection on the left-hand side.



Different types of control equipment

CAV- Control equipment LUNA d MB

In applications where the user does not want demand-controlled ventilation in the room, and has no need of communication with an external master system, a simpler form of control equipment is available. This variant of control is called LUNA and regulates the temperature in the room only (not the air quality). PARAGON Wall can be ordered with factory-mounted terminal block as well as with the loose room accessory LUNAd RE. Note that a cable connection is required between the terminal block and the actuator on PARAGON Wall and between the terminal block and LUNAd RE in the room.



Figure 13. LUNAd RE and LUNA T-CU

Versatile room controller for temperature control of air, heating and cooling

- Built-in temperature sensor and the possibility to connect an external temperature sensor
- Built-in communication port for connection to a communication bus (Modbus RTU over RS485), for reading values from a computer
- Inputs for condensation sensor or occupancy detector
- Four outputs to control heating and cooling actuators
- Three different operating modes (day, night and economy)
- If necessary, the settings can be easily changed with the help of the hand-held terminal LUNA d T-CU.

For more information, see the separate product sheet and manual for LUNAd.



Figure 14. VAV controller for demand-controlled ventilation

VAV - Control equipment for demand-controlled ventilation, heating and cooling

Occupancy in hotel rooms varies daily, but also throughout the day. The room has different needs depending on both occupancy/non-occupancy, but also individual needs depending on the individual in the room. For hotel rooms with a master system, our functional VAV controller is the best solution. It ensures the right air flow into the hotel room by means of numerous I/Os integrated into a BMS system via Modbus.

The needs of the room are managed by different sensors in the room where the controller sets different operating modes. When for example the key card (or equivalent) is activated in the room, the air flow increases from the economical low flow to the normal flow, while the temperature adjusts to the comfort level. When the room is empty, the ventilation and temperature return to economic low flow. In addition to the automatic room control, the guest can manually adjust the temperature and the air flow.

The product can be upgraded using upgrade kits but is best ordered with factory-installed VAV control equipment. See the product sheet PARAGON Wall VAV.

Technical data

Cooling capacity total, max.	2682 W
Heating capacity, water, max.	4274 W
Heating capacity, electricity,	
Length 800, max.	700 W
Length 1100, 1400, max.	1000 W
Air flow	0-85 l/s
	0-306 m³/h
Pressure range	20-200 Pa
Dimensions: Size 800, 1100, 1400	722 (+0-20)/286 mm
See the dimensional drawing for exact measurements	

Power consumption

Power consumption for transformer sizing:	VA / unit
Actuator	6
Damper motor (UM24) *	2,5
Controller (URC1) *	2
Sensor module (URC1) *	1

* *Optional Extras*

Example A:

PARAGON Wall 1100-B; = 6 VA
 6 VA for cooling - OR heating actuator when they are normally regulated in sequence.

Example B:

PARAGON Wall 1100-B; 6+6 = 12 VA
 For operating modes such as Radiator Heat and Cold draught protection power consumption will then be 6+6 VA for actuators when they are not regulated in sequence.

Recommended limit values, water

Max. recommended operating pressure (across coil only): 1600 kPa *

Max. recommended test pressure (across coil only): 2400 kPa *

* *Applicable without control equipment mounted*

Max. recommended pressure drop across the CCO valve: 20 kPa

Max. recommended pressure drop across a standard valve: 20 kPa

Min. permissible heating water flow: 0.013 l/s

Max. permissible supply flow temperature: 60 °C

Min. permissible cooling water flow: 0.04 l/s

Lowest permissible supply flow temperature: Should always be dimensioned so that the system works without condensation

Designations

P: Capacity (W, kW)

v: Velocity (m/s)

q: Flow (l/s)

p: Pressure, (Pa, kPa)

t_r: Room temperature (°C)

t_m: Mean water temperature (°C)

ΔT_m: Temperature difference [t_r-t_m] (K)

ΔT: Temperature difference, between inlet and return (K)

ΔT_i: Temperature difference, between room and supply air (K)

Δp: Pressure drop (Pa, kPa)

k_p: Pressure drop constant

Supplementary index:

k = cooling, l = air, v = heating, i = commissioning

Sizing

Easy and quick calculation of room products

Single Product Calculator "SPC" is a simple quick calculation for room products. Capacities, sounds, flows, isovels, etc. can be calculated and printouts can be made.

SPC is accessible from our product pages at www.swegon.se where there is a "Calculate" button. No login or software download needed, incredibly quick and easy!

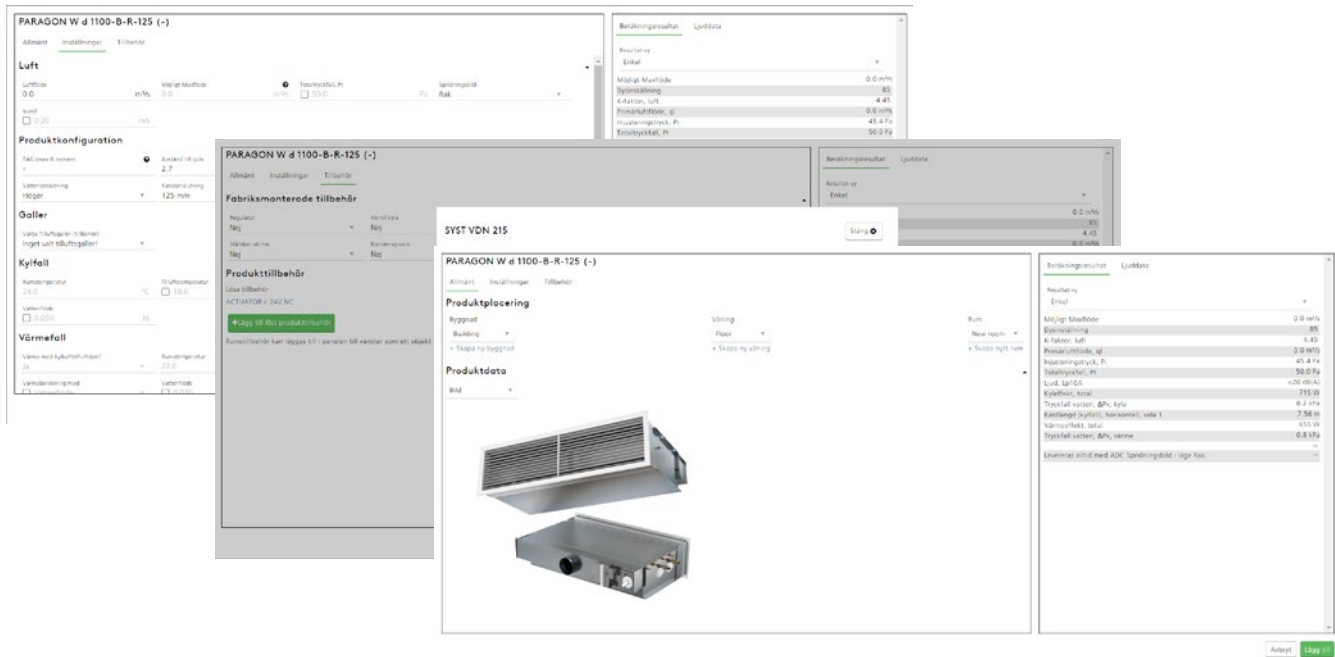

Figure 15. PARAGON Wall length 1100 for cooling and heating, water connection on the right side, factory-fitted terminal block, valves and valve actuators for cooling and heating.

K-factor setting

You can easily set the required k-factor with the help of the knob located on the back.

Example: To achieve the required flow of 25 l/s at 100 Pa, requires k-factor 2.5

- A:** Find the product's length from the left-hand side of the k-factor table.
- B:** Read the required k-factor on the row in question.
- C:** Follow the vertical row and read the number of degrees at the bottom.

K-factor table

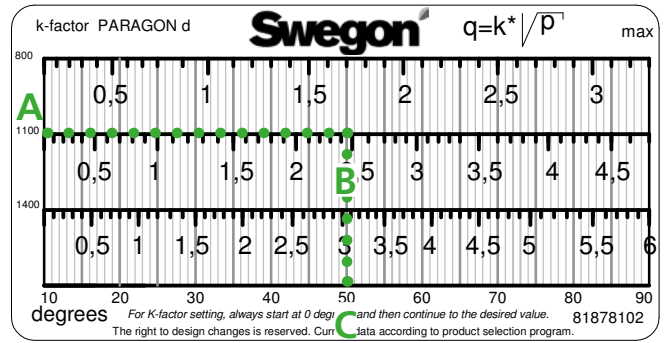

To enter settings for k-factor

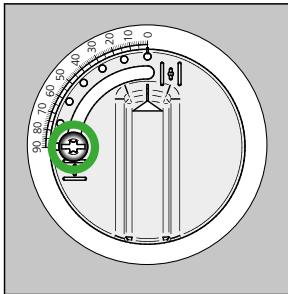

1.

Loosen the screw located in the knob's groove.

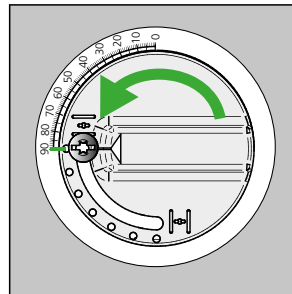

2.

The knob then moves automatically to the fully open position, 90°.

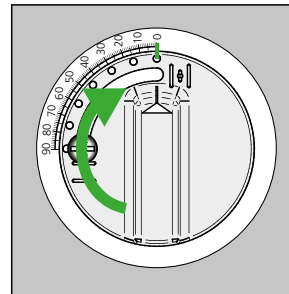

3.

Then turn the knob to the fully closed position, 0°.

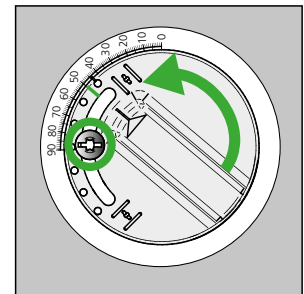

4.

Then turn the knob back to the angle for the desired k-factor (50° in our example) and tighten the screw.



Figure 16. Knob placement

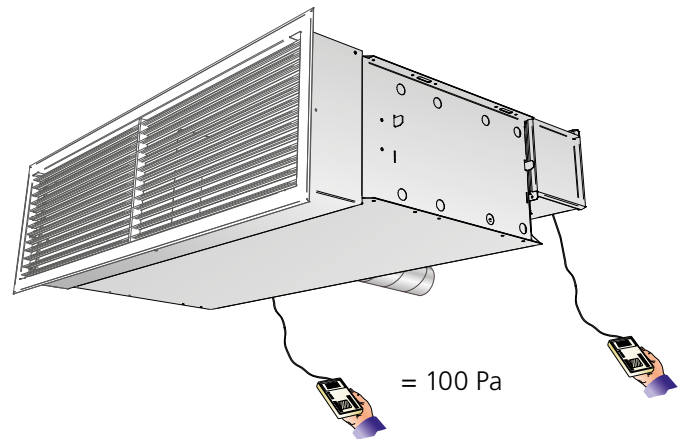

$$p_i = \left(\frac{q}{k}\right)^2 \text{ [Pa]}$$

$$q = k \cdot \sqrt{p_i} \text{ [l/s]}$$

$$\frac{q}{\sqrt{p_i}} = k$$

p_i [Pa]
 q [l/s]
 k = k-factor

Installation

Suspension

The PARAGON Wall has two holes on each short side for suspension and is mounted with a threaded rod in each hole.

For installation use the assembly fitting containing threaded rods, ceiling brackets and nuts to all four mounting brackets. Threaded rod length from 200 mm. In the event of large distances between ceiling and unit, double threaded rods with thread locks are used. Assembly fittings SYST MS M8 (Figure 18) are ordered separately.

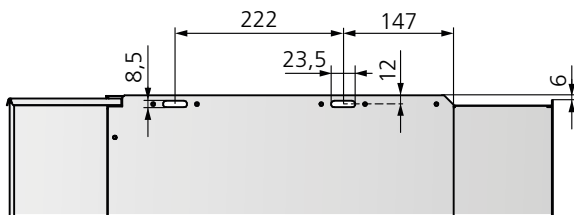

Figure 17. Dimensions suspension

Air connection

All variants have the air connection Ø125.

The air connection is centred at the rear of the product for easy access from both ends and the rear and to avoid confusing the units logistically on site.

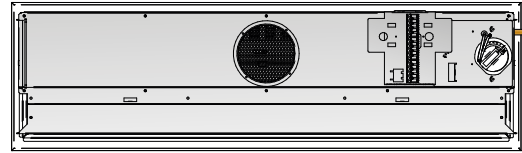

Figure 19. Centred air connection at the rear

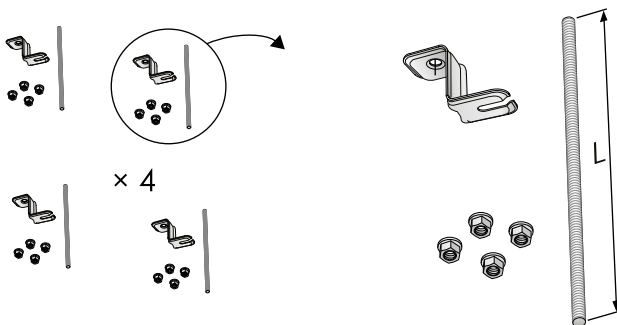

Figure 18. Assembly fitting SYST MS M8-1, ceiling mount and threaded rod

Installation

The work involving the casing can begin once PARAGON Wall has been fully installed. The product is designed to be placed at the rear of the room adjacent to the corridor and installed in the space above the suspended ceiling in the corridor.

To simplify the work, cut-out dimensions are given in separate installation instructions at www.swegon.com.

Connection - Water

Connection sizes

Standard variant with factory-fitted valves:

Length (mm)	Cooling Return	Heating Return
800, 1100, 1400	DN15 male thread	DN15 male thread

Standard variant without factory fitted valves:

Length (mm)	Cooling Supply and return	Heating Supply and return
800, 1100, 1400	plain pipe ends (Cu) Ø 12 x 1.0 mm	plain pipe ends (Cu) Ø 12 x 1.0 mm

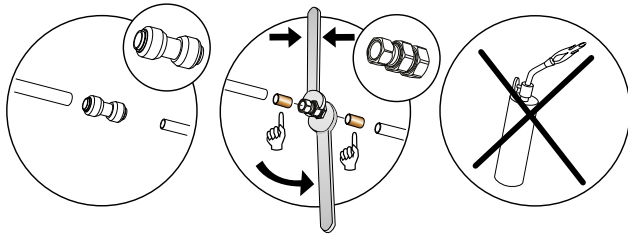

Note that compression ring couplings require support sleeves inside the pipes.

Connection of water

Connect the water pipes using push-on couplings or compression ring couplings. Note that compression ring couplings require support sleeves inside the pipes. Do not use solder couplings to connect the water pipes. High temperatures can damage the unit's existing soldered joints.

Flexible connecting hoses for water are available for flat-end pipes and valves, and can be ordered separately.

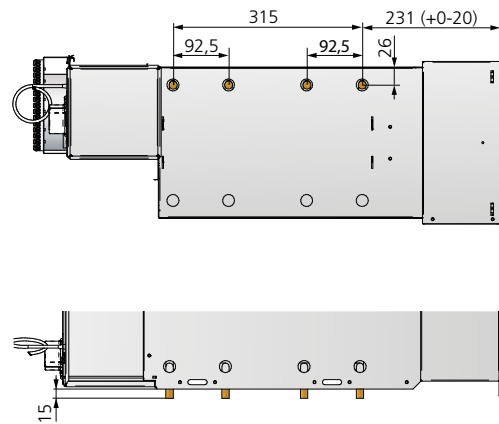
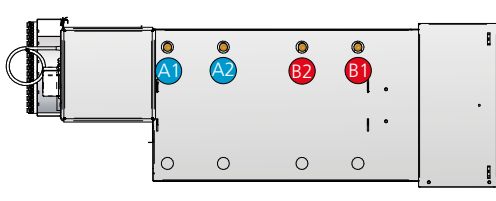

Figure 21. Dimensions water connection

Water connection on the right-hand side "R"

Cooling and heating R. all sizes



Cooling R. all sizes

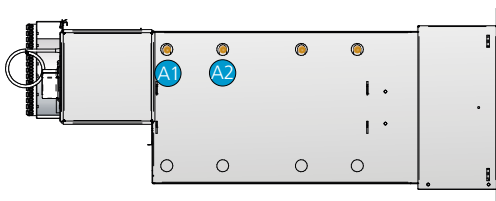
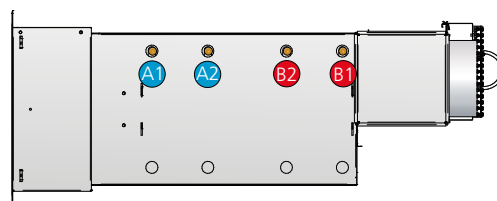

Figure 20. Water connection on right-hand side (R).

A1 = Cooling water, supply
A2 = Cooling water, return
B1 = Heating water, supply
B2 = Heating water, return

Water connection on the left-hand side "L"

Cooling and heating L. all sizes



Cooling L. all sizes

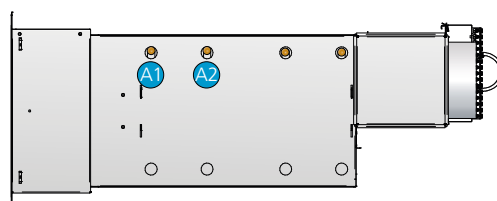

Figure 22. Water connection on left-hand side. (L).

A1 = Cooling water, supply
A2 = Cooling water, return
B1 = Heating water, supply
B2 = Heating water, return

CCO valve

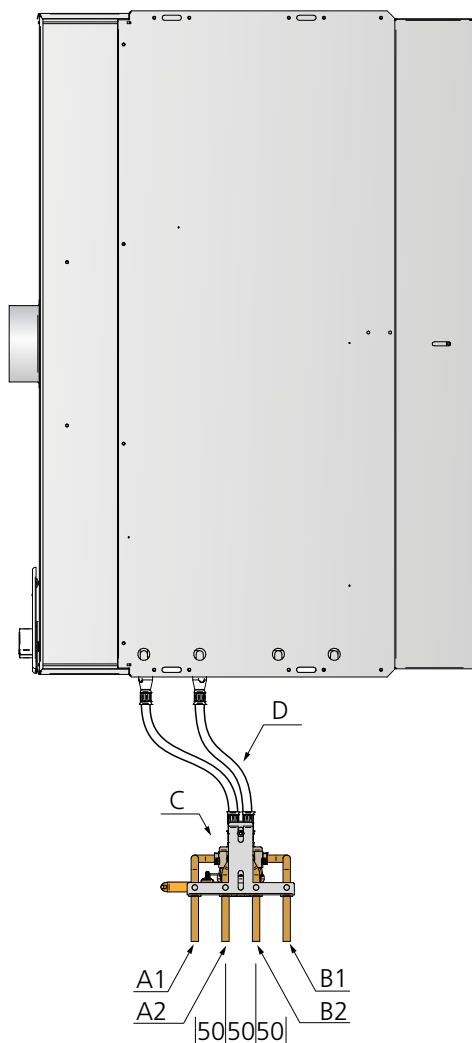

Figure 23. Water connection, CCO valve.

- A1 = Cooling water, supply
- A2 = Cooling water, return
- B1 = Heating water, supply
- B2 = Heating water, return
- C = CCO valve
- D = Flexible hose

Valves for cooling and cooling and heating

PARAGON Wall A (cooling) with valve and valve actuator

Paragon A for cooling only. The capacity of the heat exchanger is utilised optimally by maximising the cooling circuit through the coil.

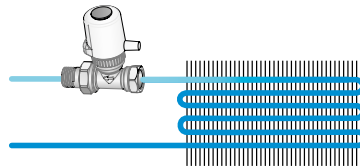

PARAGON Wall B (cooling and heating) with valves and valve actuators

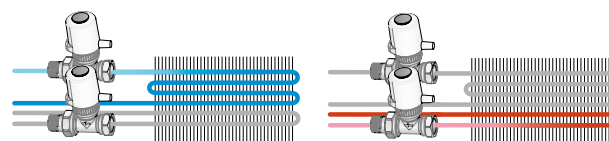

PARAGON Wall B (cooling and heating) with CCO valve

Paragon B with CCO valve Compact Change Over is used to utilise the whole coil of both cooling and heating.

Advantage:

- Permits a higher cooling water temperature and lower heating water temperature, which gives lower operating costs for the chiller and heat pump, i.e. less environmental impact.

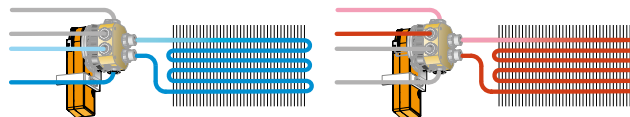

For more information about the CCO valve, see the CCO product data sheet at www.swegon.se

Accessories, control

Optional factory-fitted accessories

PARAGON Wall can be ordered with different control variants and accessories

Factory-fitted optional extras

Factory-fitted control equipment makes the installation work simple. All components are accessible from the back of the product.

A selection of our optional factory-fitted extras:

Terminal block is included when a factory-fitted accessory is installed

Module Controller	Wiring terminal PARAGON VAV RE WISE Paragon CU
Valve cooling	VDN215 Straight valve
Valve heating	VDN215 Straight valve
Actuator cooling	ACTUATOR 24 V NC
Actuator heating	ACTUATOR 24 V NC
Condensation sensor	CG IV WCD2
Temperature sensor	T-TG-1
Air quality sensor	WISE SMA

In addition to the factory-installed options, loose accessories and kits (not factory-fitted) are also available:

Kits and accessories are easily mounted during installation

A selection of our optional loose kits and accessories:

Control unit/controller	Wiring terminal PARAGON VAV RE WISE PARAGON CU LUNA RE
Pressure sensor	SYST PS
Valve cooling	SYST VDN 215 Straight valve
Valve heating	SYST VDN 215 Straight valve
Actuator cooling	ACTUATOR 24 V NC
Actuator heating	ACTUATOR 24 V NC
Valve 6-way	CCO-kit
Condensation sensor	Condensation sensor CG-IV-KIT WCD2-KIT
Temperature sensor	Temp. sensor T-TG-1 Dew-point KIT WISE Paragon
Air quality sensor	CO ₂ -Kit, Detect Qa VOC-Kit, Detect VOC-2
Temp./Occupancy detector	VAV sensor, (wall) -kit

For further information on accessories for WISE Paragon and PARAGON VAV, see current product sheets.

Accessories, factory-fitted

Wiring terminal

It's possible to control the temperature in the room, (not air quality) with a factory-fitted terminal block as well as with the loose room accessory LUNAd RE.



VAV controller

VAV controller for demand-controlled ventilation



WISE CU control unit

For integration in the WISE system as a constant flow module with control of water valves.



Valve, cooling & heating, SYST VDN 215

Factory fitted valves for cooling and heating.

The valve is mounted on the product and preset fully open.

Function	Type	Dim.	K _v (m ³ /h)
Cooling/heating	VDN215	DN15 (½")	0.07-0.89

For more information about the valve, see the separate product data sheet on www.swegon.com.



Actuator cooling & heating, ACTUATO 24 V NC

Factory fitted valve actuators for cooling and heating.

24V AC/DC, NC (Normally Closed).

For more information about the actuator, see the separate product data sheet on www.swegon.com.



Condensation sensor, WCD2

The detector operates at the dew point temperature rather than a fixed relative humidity value.

The dew-point is calculated from a temperature compensated RH element and an extremely accurate sensor element that is bound to the metal plate on the detector.

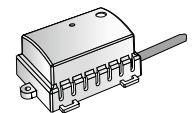

Condensation sensor, CG IV

The condensation sensor is supplied fitted and connected from the factory. The actual sensor element consists of a circuit board with gold plated conductive paths that react when condensation occurs between these. When condensation arises, the cooling valve closes the incoming water flow to the product. When the condensation on the conductive paths has been wiped off, the cooling valve is permitted to open again.

The sensor is positioned on the coil fins by the cooling supply.

For more information about the condensation sensor, see the separate product data sheet on www.swegon.com.

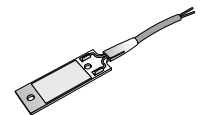

Temperature sensor, T-TG-1

For measurement of the temperature



Co₂ sensor. Detect Qa

Analogue carbon dioxide sensor that is mounted concealed, above the extract air grille.

See separate product sheet at www.swegon.com.



VOC sensor Detect VOC

Modbus connected air quality sensor that is mounted concealed above the extract air grille

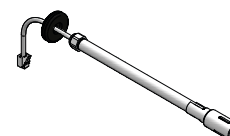

Loose accessories

Supply/extract air grille, PARAGON Wall SG/RG

Front grille for PARAGON Wall, available for products with the length, 800, 1100, 1400 mm

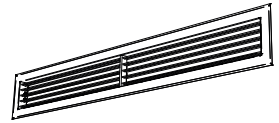

Grille lock, PARAGON T- GL

Grille lock for fixing the position of the supply air grille.



Transformer, Power ADAPT 20 VA (ARV)

Input voltage 230 V, 50-60 Hz, Output voltage 24 V AC
Power 20 VA, Enclosure IP33



Transformer, SYST TS-1

Double-insulated protective transformer 230 V, AC/24 V AC
Input voltage 230 V, 50-60 Hz, Output voltage 24 V AC,
Power 20 VA, Enclosure IP33

For more information, see the separate product data sheet on www.swegon.com.

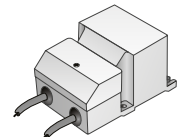

Temperature sensor, T-TG-1

External temperature sensor. Used for example if the room temperature must be measured elsewhere than at the sensor module, or to measure the temperature of the main pipe in change-over systems.

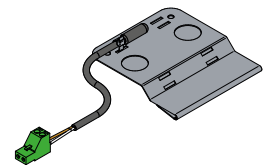

Valve, SYST VDN 215

Straight valves for cooling and heating.

VDN215 is preset fully open on K_v 0.89.

For more information about the valve, see the separate product data sheet on www.swegon.com.

Function	Type	Dim.	K_v (m ³ /h)
Cooling/ heating	VDN215	DN15 (½")	0.07-0.89



Valve actuator, cooling & heating, ACTUATORc 24 V NC

Valve actuators for cooling and heating.

24V AC/DC, NC (Normally Closed).

For more information about the actuator, see the separate product data sheet on www.swegon.com.



Cable, SYST CABLE RJ12 6-LED.

Cable for the connection of an external sensor module to the controller or between sensor modules. Available in different standard lengths.



Cable, CABLE CONVERTER USB-RJ12 (RS485)

Cable with integrated modem to connect a PC to the controller. Needed to run e.g. SWICCT or ModbusPoll.



Cable adapter, ADAPTER RJ12-WIRE

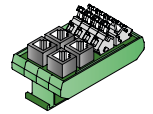

LINK Wise

Network cable for Modbus communication in the WISE system. The cable conforms to EIA 485 standard. Shielded four conductor AWG 24, external diameter Ø 9.6 mm, Grey PVC. The cable is only supplied in reels of 500 m.



Co₂ sensor. Detect Qa

Analogue carbon dioxide sensor that is mounted concealed, above the face plate. See separate product datasheet at www.swegon.com.



VOC sensor Detect VOC

Modbus connected air quality sensor that is mounted concealed above the face plate.

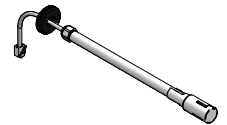

Assembly fitting, SYST MS M8

For installation use the assembly fitting containing threaded rods, ceiling brackets and nuts to all four mounting brackets.

Threaded rod length from 200 mm. In the event of large distances between ceiling and unit, double threaded rods with thread locks are used.



Flexible connection hoses, SYST FH

Flexible hoses are available with quick-fit, push-on couplings as well as clamping ring couplings for quick and simply connection. The hoses are also available in various lengths. Note that compression ring couplings require support sleeves inside the pipes.

Flexible hoses also reduce the risk of movement in the piping system due to thermal expansion.

F1 = Clamping ring couplings at both ends.

F20 = Push-on couplings at both ends.

F30 = Push-on coupling at one end and union nut G20ID at the other end.

F4/F5 = Clamping ring coupling at one end and union nut with flat seal at the other end.

F40 = Push-on coupling at one end, union nut 90° at the other end.

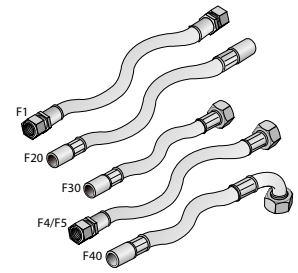

Venting nipple, SYST AR-12

A venting nipple is available as a complement to the flexible hoses with push-on couplings. The venting nipple fits directly in the push-on hose coupling and can be fitted in an instant.

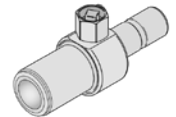

Connection piece, air – insertion joint, SYST AD1

SYST AD1 is used as a joint between PARAGON VAV and the duct system. Available in two sizes: Ø125 and Ø160 mm.



Connection piece, air, SYST CA

90° duct bend

Available in two sizes: Ø125 and Ø160 mm.



Supply Air Kit 125

Supply air kit contains sound attenuator CLA, d=125 mm and sleeve.

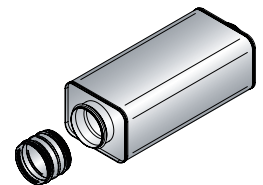

Extract Air Kit CAV-CRP-125

Extract air kit for CAV containing sound attenuator CLA, d=125, manual commissioning damper, control valve EXC.

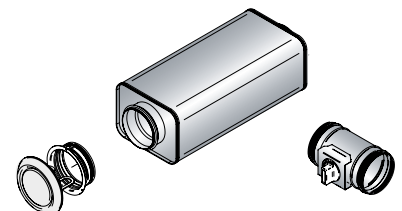

Accessory kits

Condensation sensor, Condensation sensor CG-IV-KIT

Condensation sensor CG-IV and assembly parts for retrofitting.

The condensation sensor's sensor element consists of a circuit board with gold plated conductive paths that react when condensation occurs between these. When condensation arises, the cooling valve closes the incoming water flow to the product. When the condensation on the conductive paths has been wiped off, the cooling valve is permitted to open again.

Sensor is positioned on the coil fins by the cooling supply.

For more information about the condensation sensor, see the separate product data sheet on www.swegon.com.

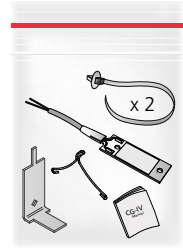

Condensation sensor WCD2-KIT

Condensation sensor WCD2 and assembly parts for retrofitting.

The detector operates at the dew point temperature rather than a fixed relative humidity value.

The dew-point is calculated from a temperature compensated RH element and an extremely accurate sensor element that is bound to the metal plate on the detector.

For more information about the condensation sensor, see the separate product data sheet and installation instructions on www.swegon.com.

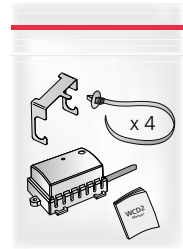

Temp. sensor T-TG-1

Temperature sensor for measuring temperature



PARAGON VAV RE-KIT

Control kit for upgrading to VAV

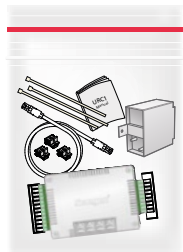

6-way valve, CCO

Compact Change Over valve, for maximum utilisation of the coil and thus high cooling and heating capacity.

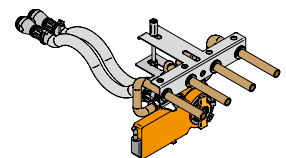

Upgrade kit for WISE

UPGRADE KITS WISE PARAGON CU

Control kit for upgrading to WISE

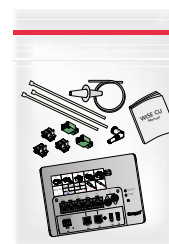

Upgrade kit WISE Condensation sensor CG IV-KIT

The upgrade kit contains condensation sensor, CG IV and fastening details

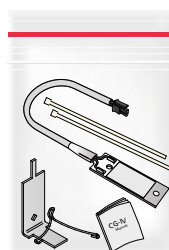

Upgrade kit Dew-point KIT WISE PARAGON

The upgrade kit contains the temperature sensor, WISE TEMP SENSOR PT1000



Upgrade kit WISE SMA

The upgrade kit includes WISE SMA incl. RJ12 cable and assembly plate.



Dimensions and weights

Weight

PARAGON Wall 800

Length mm	Type	Dim. Ø	Dry weight* (kg)		Water volume (l)	
			Without grille	incl. grille	cooling	heating
800 R	A	125	17.4	19.6	1.39	
800 L	A	125	17.4	19.6	1.38	
800 R	B	125	17.4	19.6	1.39	0.38
800 L	B	125	17.4	19.6	1.38	0.37
800 R	X	125	17.4	19.6	1.39	
800 L	X	125	17.4	19.6	1.39	

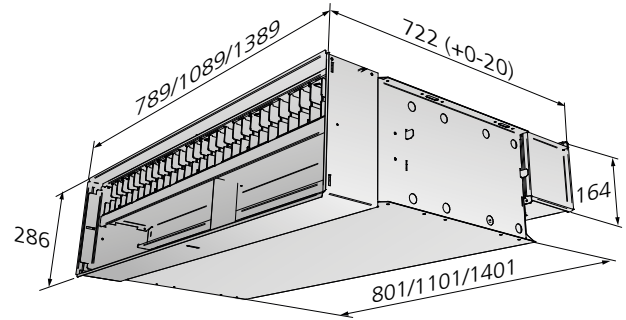

Figure 24. Dimensional drawing without grille

PARAGON Wall 1100

Length mm	Type	Dim. Ø	Dry weight* (kg)		Water volume (l)	
			Without grille	incl. grille	cooling	heating
1100 R	A	125	22.6	25.5	1.93	
1100 L	A	125	22.6	25.5	1.92	
1100 R	B	125	22.6	25.5	1.93	0.52
1100 L	B	125	22.6	25.5	1.92	0.51
1100 R	X	125	22.6	25.5	1.93	
1100 L	X	125	22.6	25.5	1.92	

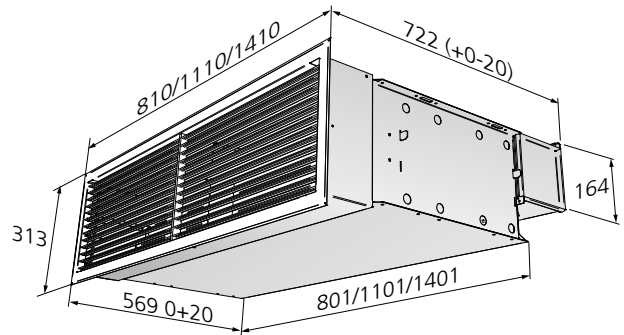

Figure 25. Dimensional drawing with grille

PARAGON Wall 1400

Length mm	Type	Dim. Ø	Dry weight* (kg)		Water volume (l)	
			Without grille	Incl. grille	cooling	heating
1400 R	A	125	27.6	31.2	2.47	
1400 L	A	125	27.6	31.2	2.46	
1400 R	B	125	27.6	31.2	2.47	0.65
1400 L	B	125	27.6	31.2	2.46	0.64
1400 R	X	125	27.6	31.2	2.47	
1400 L	X	125	27.6	31.2	2.46	

*Added weight for air diffuser: 0.26 kg

Specification

Specification, PARAGON Wall

Comfort module type PARAGON for cooling, heating, ventilation and control.

Delivery demarcation PARAGON Wall

Swegon's limits of supply are at the connection points for water.

At these connection points, the RE pipework contractor connects to plain pipe end and/or male threads towards valves, fills the system, bleeds it and tests the pressure in the circuits.

The ventilation contractor connects to the duct connections with dimensions as specified on the basic size drawing in the section "Dimensions".

EE electrical equipment contractor provides a 24 V AC network power supply or earthed 230 V outlets for a transformer, as well as a junction box, if required, installed in a wall for a room thermostat.

The building contractor cuts the openings in corridor wall for the supply air duct, in the interior wall and suspended ceiling for the supply air and extract air grilles and in the bathroom ceiling for the extract air duct.

The electrical contractor connects the power (24V) and signal cables to the connection terminals with spring-loaded snap-in connections.

Maximum cable cross section 2.5 mm². For safe operation, we recommend cable ends with ferrules.

Maintenance

Ideally the product should be cleaned twice a year by vacuuming the coil to remove loose dust.

In fibre-dense environments, an initial cleaning is recommended, about three months after use. Thereafter, cleaning is recommended at an interval of one to two times per year. A simple visual inspection of connections is recommended when cleaning.

For cleaning grilles and other painted surfaces: Avoid aggressive cleaning agents which may harm painted surfaces. Normally a mild soap or alcohol solution is fully adequate for cleaning. See also previous maintenance section in the Instructions for Use.

Ordering key PARAGON Wall

PARAGON Wall	d	aaa-	bb-	c-	125
Version:					
Length (mm)					
800, 1100 and 1400					
Function:					
A = Cooling					
B = Cooling and heating (water)					
X1 = Cooling and electric heating					
Length: 800 = 350W					
Length: 1100/1400 = 500W					
X2 = Cooling and electric heating					
Length: 800 = 700W					
Length: 1100/1400 = 1000W					
Connection side - water					
(seen from the back of the product)					
R - Right					
L - Left					
Air connection					
Ø125					

Factory-fitted optional extra

Control unit/controller	Wiring terminal PARAGON VAV RE WISE PARAGON CU
Valve cooling	SYST VDN 215 Straight valve
Valve heating	SYST VDN 215 Straight valve
Actuator cooling	ACTUATOR 24 V NC
Actuator heating	ACTUATOR 24 V NC
Condensation sensor	CG IV WCD2
Temp. sensor	T-TG-1
Air quality sensor	WISE SMA

Available to order, kit and accessories

In addition to the factory-installed options, loose accessories and kits (not factory-fitted) are also available:

Kits and accessories are easily mounted during installation

Control unit/controller	Wiring terminal PARAGON VAV RE WISE PARAGON CU LUNA RE
Pressure sensor	SYST PS
Valve cooling	SYST VDN 215 Straight valve
Valve heating	SYST VDN 215 Straight valve
Actuator cooling	ACTUATOR 24 V NC
Actuator heating	ACTUATOR 24 V NC
Condensation sensor	Condensation sensor, CG IV-KIT WCD2-KIT
Temperature sensor	T-TG-1-KIT Dew-point KIT WISE Paragon
Air quality sensor	CO ₂ -Kit, Detect Qa VOC-Kit, Detect VOC-2 WISE SMA
Temp./Occupancy detector	VAV sensor, (wall) -kit
Supply and return air grille	PARAGON T-SG/RG
Grille lock	PARAGON T-GL
Transformer	Power ADAPT 20 VA (ARV)
"	SYST TS-1
Card switch	SYST SENSO II
Assembly piece	SYST MS M8
Flexible hoses	SYST FH
Valve, 6-way	CCO-Kit
Venting nipple	SYST AR-12
Connection fitting, air – nipple	SYST AD1
Connection fitting, air – elbow	SYST CA
Supply air kit	Supply Air Kit 125
Extract air kit	Extract Air Kit CAV-CRP-125
ADC	ADC-2-105

Ordering Key, Accessories

Grille	PARAGON d T-	aa-	bbbb
Type: SG/RG = Supply/return air grille			
Length of the product (mm): 800, 1100, 1400			

Assembly fitting	SYST MS M8	aaaa-	b
Length threaded rod (mm): 200; 500; 1000			
Type: 1=One threaded rod 2=Two threaded rods and one thread lock			

Flexible connection hose, (x1)	SYST FH F1-	aaa-	12
Compression ring (Ø12 mm) against pipe at both ends (excl. support sleeves)			
Length (mm): 300, 500, 700			

Flexible connection hose, (x1)	SYST FH F20-	aaa-	12
Quick-connector push-on (Ø12 mm) against pipe at both ends			
Length (mm): 275, 475, 675			

Flexible connection hose, (x1)	SYST FH F30-	aaa-	12
Quick-fit coupling, push-on (12 mm dia.) against pipe on one end, G20ID sleeve nut on the other end.			
Length (mm): 200, 400, 600			

Accessory kits:

- Controller KIT PARAGON VAV RE xx items
- Controller KIT TERMINAL KIT xx items
- Controller KIT WISE PARAGON CU xx items
- Controller KIT LUNA RE xx items
- Condensation sensor KIT for retrofitting
Condensation sensor CG IV-KIT, xx items
- Condensation sensor for retrofitting, WCD2-KIT, xx items
- Temp. sensor, T-TG1-KIT, xx items
- Dew-point KIT WISE Paragon, xx items
- Valve, 6-way, CCO-Kit, xx items
- Supply air kit, Supply Air Kit-125 xx items
- Extract air kit, Extract Air Kit CAV-CRP-125 xx items
- Air quality sensor, CO2-Kit, Detect Qa, xx items
- Air quality sensor, VOC-Kit, DETECT VOC-2

Accessories:

- Supply/return air grille, PARAGON dT-SG/RG-aaaa xx items
- Grille lock, PARAGON T-GL xx items
- Valve cooling SYST VDN 215 xx items
- Actuator cooling ACTUATOR 24 V NC, xx items
- Transformer, POWER Adapt 20 VA, xx items
- Transformer, SYST TS-1, xx items
- Pressure sensor, SYST PS, xx items
- Assembly piece, SYST MS M8 aaaa-b
- Cable adapter, ADAPTER RJ12-WIRE, xx items
- ADC for subsequent installation, SYST ADC-2-105, xx items
- Flexible connection hose, SYST FH F1 aaa- 12 xx pcs.
- Flexible connection hose, SYST FH F20 aaa- 12 xx pcs.
- Flexible connection hose, SYST FH F30 aaa- 12 xx pcs.
- Venting nipple, push-on, SYST AR-12, xx items
- Connection piece, air – nipple, SYST AD1-aaa, xx items
- Connection piece, air (90°elbow), SYST CA-aaa-90, xx items

etc.

Specify the quantities individually or with reference to the drawing.

Ordering examples

Example:

PARAGON Wall in length 1100 with cooling and heating function. Water connection on the right-hand side and an air connection Ø125 and supply/return air grilles

PARAGON Wall d 1100-B-R-125

PARAGON d T-SG/RG-1100

Specification text

Example of a specification text according to VVS AMA.

PCT.312 Duct connected chilled beams.

PTD.4 Duct connected room devices for heating and cooling

KB XX

Comfort module PARAGON Wall with integrated supply air damper in the product. Designed for rear-edge mounting in the wall with the following functions:

- Waterborne cooling
- Waterborne heating or electric heating
- Ventilation
- Comfort guarantee ADC with adjustable function +-30 degrees
- Ø125 mm duct connection
- Integrated circulating air opening in face plate
- Coil and any control equipment are accessible via the rear of the product
- Cleanable
- Fixed measurement tapping with hose
- Eurovent certified
- Grilles in standard colour RAL 9003

Contractor demarcation at connection point for water and air as in outline drawing.

- At the points of connection the pipe contractor connects to 12 mm plain pipe end after which the ventilation contractor connects the Ø125 mm insertion piece (sleeve).
- The pipe contractor fills, bleeds, tests the pressure and assumes responsibility for the design water flows reaching each branch of the system and the unit.
- The ventilation contractor conducts initial commissioning of the air flows