



HPN Series

High pressure humidifiers



Energy saving

Energy-efficient adiabatic humidifier



Distribution

Rack with configurable number of nozzles



Minimal maintenance

Works with demineralised water



Germ-free

VDI 6022-1 certification guarantees no risk of bacterial proliferation



Variable speed management

Equipped with an EVCO inverter installed in the electrical compartment and physically separated from the hydraulic unit

- Humidity distributed into an AHU or the room
- Number of nozzles customisable (4 l/h or 8 l/h)
- Constant 80 bar pressure irrespective of number of nozzles
- Tiny particles produced (15 µm)
- Stainless steel pumping system
- EVCO controller with an EPcolor interface on the hydraulic unit and an EVCO controller with an EV3 interface on the distribution rack
- Pump control with instant viewing of operational parameters

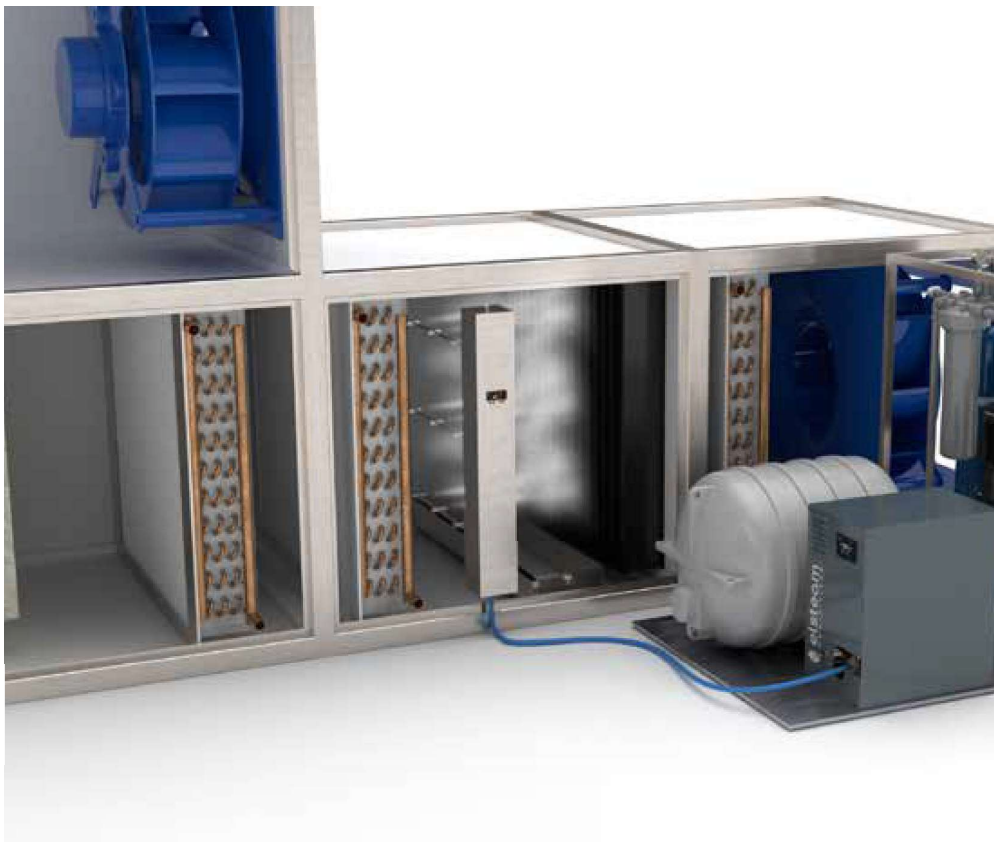

The humidifiers in the HPN series deliver steam into the room using a customisable distribution system, or directly into an AHU, using distribution racks with a configurable number of branches and nozzles. Several AHUs can be served by a single humidifier by connecting the hydraulic unit to multiple distribution racks. Each rack has its own controller connected to the AHU humidity sensor. Depending on the production requirement of each rack, the precision control of the hydraulic unit keeps the pressure of the fluid constant (8 MPa), producing mist with a particle size of around 15 μm , irrespective of the size of the rack.

Steam distribution racks

Distribution racks are available in three different heights; Distribution racks are available in three different heights; the length of the branches is variable and nozzle size may be 4 l/h or 8 l/h. The number of nozzles can be customised to the client's needs. The EVCO controller installed on the rack gives proportional control of the opening of the nozzles. Built entirely in stainless steel, the distribution system automatically controls the solenoid valve to discharge water, meeting the hygiene requirements of VDI 6022-1.

Construction details

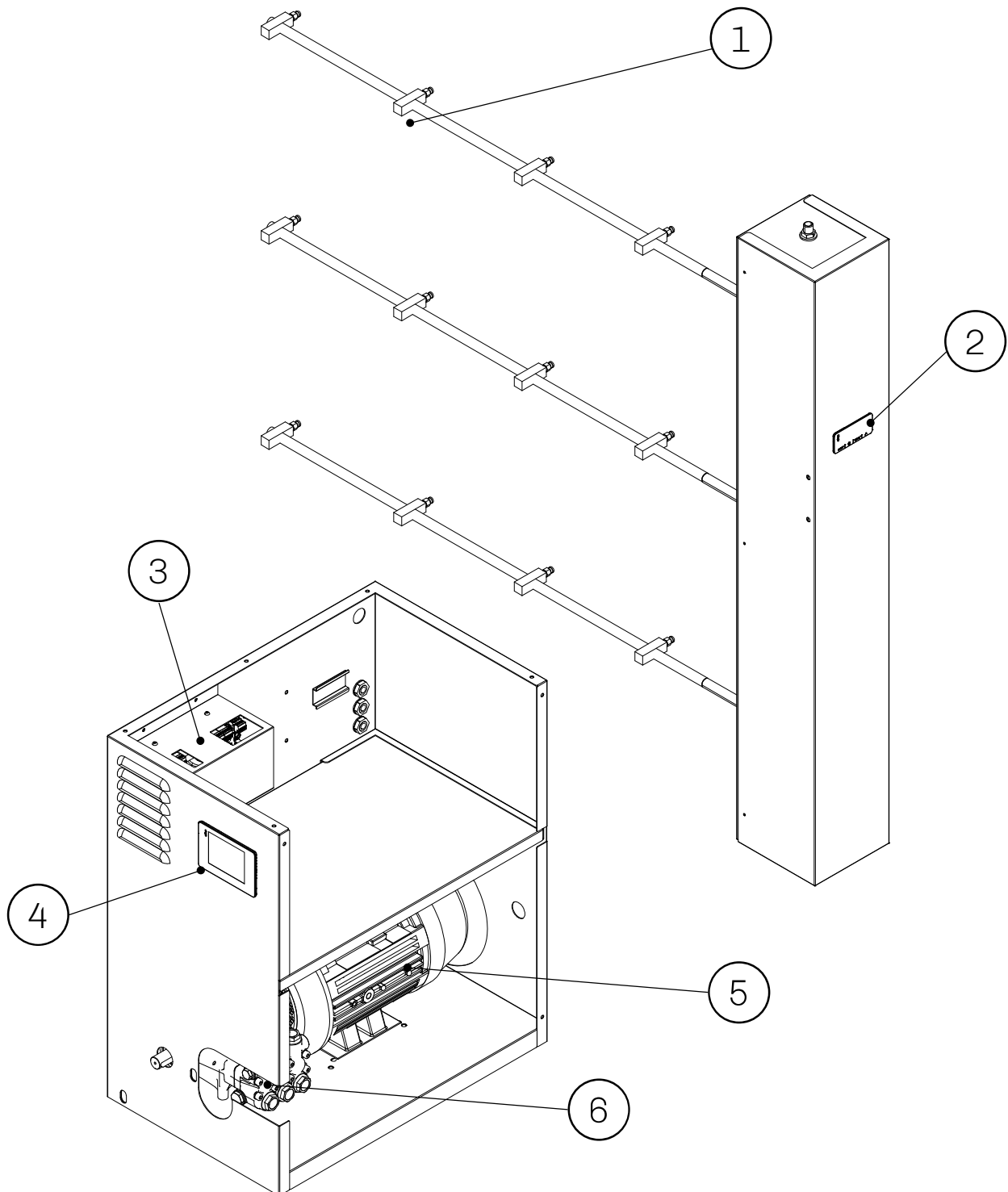

1. Nozzle

2. EV3 remote controller on rack

3. COMPACT inverter

4. EPJ controller

5. Motor

6. High-pressure pump

Ideal in the following applications

Residential and commercial environments

Comfort in our homes depends largely on creating the ideal climate, which science has established as being 20-24° C for temperature and 40-60 % for relative humidity. In winter in particular, when buildings are heated, the level of relative humidity can fall drastically. Skin and mucous membranes can become dry, allergies and respiratory tract infections are more likely to develop and unwanted microorganisms like bacteria and viruses can proliferate. Dry air can also affect our perception of the temperature (lower than it really is in winter), make us feel tired and cause a drop in concentration. Maintaining the right level of humidity is therefore crucial to ensure personal health and wellbeing, in the workplace too.

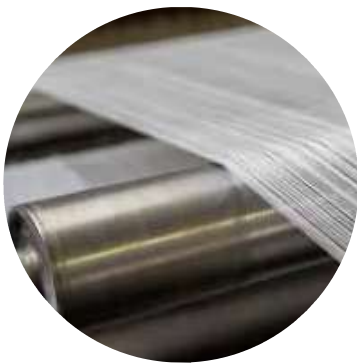

Textile industry

Keeping air humidity within the parameters required for each particular product improves the quality of the fabric, process efficiency and productivity, as the yarns are more elastic, less prone to tearing (even when using high-speed looms) and produce less lint. The fabrics lose considerably less weight and static electricity, which attracts dust, is eliminated so machine performance is enhanced.

Paper and printing industry

Paper is extremely sensitive to moisture in the air and, when it is being processed, humidity levels must be controlled very carefully. Once the paper has dried, it is wound into spools which can become distorted or tear if the air is too dry and this has repercussions on the subsequent stages in the process. In the printing industry, if humidity levels are too low, errors can occur during printing due to paper distortion, sheets of paper can stick together due to a build-up of dust and static electricity on the machinery can cause serious issues.



Ideal in the following applications

Food industry

Industrial production of flour, pasta and baked goods can be affected when there is not enough moisture in the atmosphere. If the temperature tends to rise during production, the ingredients, whose water content is dependent on the humidity in the surrounding atmosphere, can quickly lose water, with repercussions on their weight and quality. Cold steam generated by an adiabatic humidification system specially designed to ensure hygienic conditions during production, is the ideal, cost-effective solution for lowering the temperature while humidifying large food production departments.



Biomedical industry

Components in engineering plastics for medical use, whether they are single use or otherwise, are manufactured in a protected atmosphere, where temperature and humidity levels are kept constant to prevent any variations in quality and size that may occur during the transformation process of hygroscopic polymers. This environment also ensures machinery a long life and efficiency, reducing friction and electrostatic charge. Thanks to VDI 6022-1 certification, the energy-efficient adiabatic humidification of HPN products also reduces the risk of bacterial proliferation in aseptic environments where biomedical products are produced and stored.

Greenhouses, botanical gardens and farms

The microclimate in greenhouses must be kept at constant, optimal levels to increase productivity and minimise water consumption. Humidification plays a key role in maintaining ideal conditions, especially for plants (tropical plants, mushrooms, etc.) which absorb moisture from the air around them. Misting systems are ideal for ensuring the right microclimate both in winter, when relative humidity falls due to heating in the greenhouse, and in summer because the cold mist cools and humidifies at the same time, according to the adiabatic principle. Misting systems are also an efficient, cost-effective solution for cooling barns: heat stress reduces productivity on farms, having a negative effect on the animals' appetite, mortality rate, fertility and growth.



Models available and technical features

Models		HPN2L DEMI	HPN3L DEMI	HPN4L DEMI	HPN5L DEMI	HPN6L DEMI	HPN7L DEMI	HPN8L DEMI	HPN9L DEMI	HPN11L DEMI	HPN14L DEMI
SPRAY PRODUCTION											
Production capacity	[kg/h]	120	180	240	300	360	420	480	540	660	840
Maximum pressure	[MPa/ bar]	8/80	8/80	8/80	8/80	8/80	8/80	8/80	8/80	8/80	8/80
SPRAY DISTRIBUTION											
Distribution rack (HPNxRACKxxx)		Customisable									
Maximum number of nozzles (4 l/h) controlled by the humidifier	[n]	30	44	60	74	90	104	120	134	164	210
Maximum number of nozzles (8 l/h) controlled by the humidifier	[n]	15	22	30	37	45	52	60	67	82	105
ELECTRICAL PROPERTIES											
Power consumption	[kW]	1,5	1,5	1,5	1,5	1,5	1,5	2,2	2,2	4	4
Power supply	[VAC, Hz]	230, 50/60	230, 50/60	230, 50/60	230, 50/60	230, 50/60	230, 50/60	230, 50/60	230, 50/60	400, 50/60	400, 50/60
Phases	[n]	1	1	1	1	1	1	1	1	3	3
WATER PROPERTIES											
Inlet water quality		Complies with microbiological standards for drinking water established by German standard (TrinkwV) and demineralised (completely or partially) water from drinking water. A VDI 6022 non return valve must be installed if non-demineralised water is used									
Inlet water conductivity	$\mu\text{S}\cdot\text{cm}$	0...100									
Inlet water hardness	°f	0...5									
Inlet water pressure	[MPa/ bar]	0.02...14/0.2...10									
Inlet water connection		M 3/4" GAS									
Water drain external dimensions		M 1/4" GAS									
GENERAL CHARACTERISTICS											
Dimensions	WxHxD [mm]	515x600x335						660x600x335			
Weight	[kg]	50									
Main unit protection		IP20									
Distribution rack protection		IP40									
REGULATION											
Type of controller		built into hydraulic unit, remote on distribution rack									
Command signal		4... 20 mA (built-in controller), 0-10 V or ON-OFF (remote controller)									

Accessories

DISTRIBUTION RACK	
HPNxRACKxxx	customisable distribution rack
MIST ELIMINATOR	
HPNDROPXX	mist eliminator, various sizes
HOSES TO LOAD WATER	
0017020016	flexible hose 3/8 " GAS female that connects the distribution rack (by the meter)
HPNK03/04/05/06/07	unit/rack water inlet hose in engineering plastic, length 2 m-15 m
HPNK13/14/15/16/17	stainless steel unit/rack water inlet hose, length 2 m-15 m
REGULATIONS	
EV3411M7	single output electronic controller, power supply 230 VAC, multi-sensor analogue input
PROBES	
EVHP523	humidity transducer, power supply 8 ... 28 VDC, 1 x 4-20 mA provided signal
EVHTP523	humidity and temperature transducer, power supply 8 ... 28 VDC, 2 x 4-20 mA provided signal
EVTNW30F200	NTC probe, thermoplastic cable, 2 wires, 3 m length, 5 x 20 mm overmoulded bulb, IP68 protection
REVERSE OSMOSIS SYSTEMS	
EHRO200	200 l/h reverse osmosis system
EHRO300	300 l/h reverse osmosis system
EHRO400	400 l/h reverse osmosis system