



Krantz

Circular displacement outlet
with adjustable damper VA-ZD....

Air distribution systems

Krantz

Circular displacement outlet VA-ZD

Construction design and function

Preliminary remarks

Displacement air outlets from Krantz can be used effectively to remove airborne pollutants and thermal loads from production and work areas and without excessive mixing with indoor air. In this way, it is possible to reach lower pollutant levels and thermal loads than with a turbulent mixed ventilation system¹⁾.

The circular displacement outlet with adjustable damper by Krantz is eminently suited for installation above the occupied zone or on the floor.

If the outlet is placed at about 3 m height, a pollutant load factor of 55 to 57% can be achieved (against 90 to 100% with turbulent mixing ventilation), depending on the outlet setting. If it is placed on the floor, the pollutant load factor is as low as about 20%. The thermal load factor is likewise low: it amounts to about 65% with the outlet at 3 m, and about 45% with a floor placement.

The discharge direction can be continuously adjusted, from slightly inclined upwards to vertically downwards. As a result, it is easy to achieve optimum indoor air flow at varying levels of room heating.

The adjustment of the discharge direction can be done manually (with control lever, chain pull, or Bowden cable), with an electric actuator, or via automatic, non-externally-powered, active thermal control devices.

Construction design and function

The main components of the circular displacement outlet with adjustable damper are the perforated cylinder **1** with connection spigot **2** and plain bottom **3**, the orifice rings **4**, and the air deflection tube **5** with built-in adjustable damper **6**. The outlet is made of galvanized sheet metal.

Owing to its particular design the perforated cylinder generates a low-turbulence displacement flow around the air outlet.

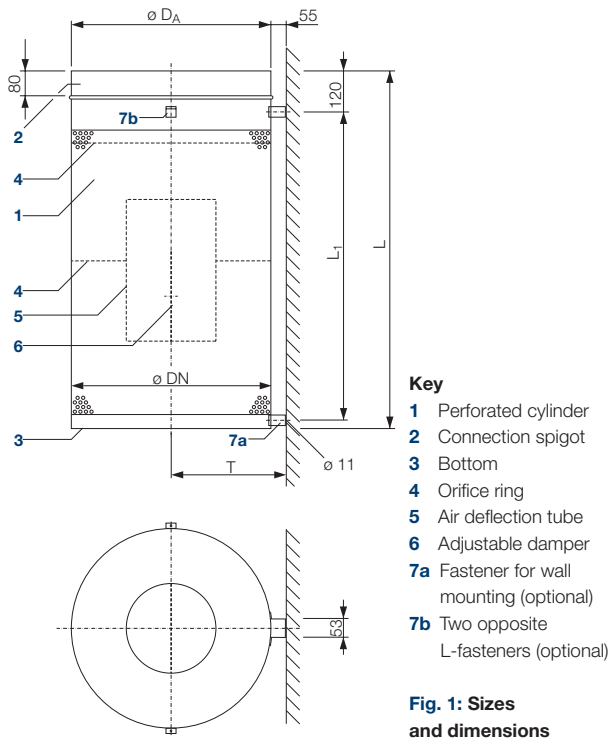

Fig. 2: Circular displacement outlet with adjustable damper
left: adjustment with control lever
right: adjustment with Bowden cable

Size	Volume flow rate for placement								Dimensions				Weight kg
	at 3 m height				on the floor				ϕD_A mm	L mm	L_1 mm	T mm	
	$\dot{V}_{A \min}$ l/s	$\dot{V}_{A \min}$ m ³ /h	$\dot{V}_{A \max}$ l/s	$\dot{V}_{A \max}$ m ³ /h	$\dot{V}_{A \min}$ l/s	$\dot{V}_{A \min}$ m ³ /h	$\dot{V}_{A \max}$ l/s	$\dot{V}_{A \max}$ m ³ /h					
250	195	700	475	1700	140	500	330	1200	249	900	765	180	10
315	305	1100	725	2600	220	800	475	1700	314	900	765	212	11
355	415	1500	975	3500	305	1100	670	2400	354	1100	965	232	12
450	695	2500	1530	5500	485	1750	1055	3800	449	1100	965	280	14
560	1055	3800	2220	8000	750	2700	1550	5600	559	1100	965	335	18
630	1400	5000	2800	10000	970	3500	1950	7000	629	1100	965	370	21

¹⁾ Pollutant load factor = ratio of pollutant concentration at the workplace to pollutant concentration in the return air, in %.
 Heat load factor = ratio of heat load at the workplace to total heat gains, in %.

Circular displacement outlet VA-ZD

Placement

For even supply air flow and thus higher thermal comfort to increase thermal comfort, the outlet type for floor placement has finer perforations and works with reduced air flow rate (70% against type for placement at 3 m height). The air deflection tube and the adjustable damper enable the continuous alteration of the air discharge direction from a slight incline upwards (cooling mode) to vertically downwards (heating mode). The damper can be adjusted manually, by an electric actuator, or by a thermal control unit. For manual adjustment there are 3 options available: a Bowden cable, a chain pull, or a control lever which will be positioned on the outlet surface.

Thermal adjustments can be made either alone through the supply air temperature or through the temperature difference between supply air and indoor air. The latter is for cases in which the temperatures lie outside the working range of the thermal adjustment element for supply air.

Air outlet placement

The air outlet can be placed either above the occupied zone or on the floor (Fig. 3), anywhere in the room or in front of a wall or pillar.

a) Placement **above the occupied zone**

In spaces with low specific heat loads or where heavy pollutants are released, the air outlets are best placed above the occupied zone. The air is supplied from above (Fig. 3, top). The recommended discharge height is 3 m (underside of air outlet). The removal of heavy pollutants is facilitated by the extraction of about 50% of the return air at floor level.

b) Placement **on the floor**

This arrangement is best suited either for removing high specific heat loads ($\dot{q} > 120 \text{ W/m}^2$) or where light pollutants are released. The direction of the supply air jets supports the buoyancy forces and helps convey the light pollutants away to the return air ducts. The air outlet can be placed either directly on the floor or on a customer supplied base having a maximum height of 0.5 m (Fig. 3, bottom). For this arrangement the outlet has a finely perforated cylinder.

The distance between the air outlet and the next workplace can be seen in graph 5 (page 7).

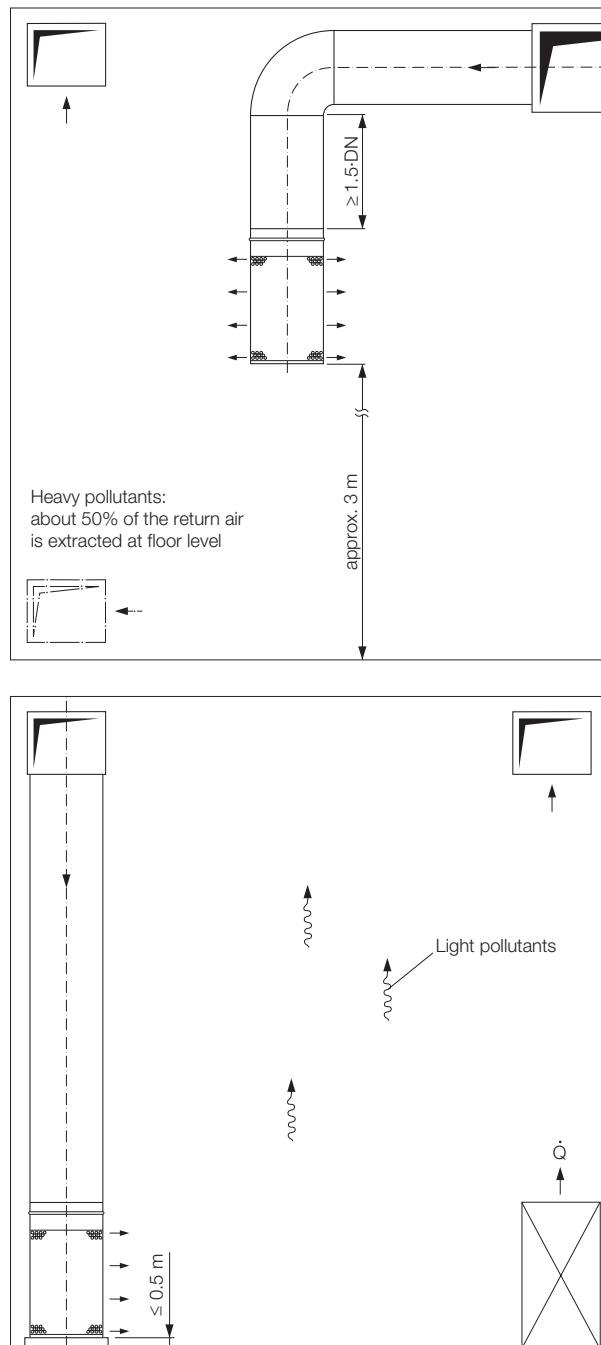

Fig. 3: Examples of placement
top: above the occupied zone
bottom: on the floor

Circular displacement outlet VA-ZD

Air jet dispersion

Air jet dispersion

Cooling mode: With the adjustable damper open, a partial volume of air gets through the deflection tube to the outlet bottom where it is deflected before being discharged slightly upwards (Fig. 4, Cooling). This lifts the complete air stream and increases the height of the supply air layer. Whether the outlet is placed above the occupied zone or on the floor, an even low-turbulence displacement flow builds up around the air outlet, with a large penetration depth into the occupied zone.

Heating mode: Through the air guiding device integrated into the displacement air outlet, thermal buoyancy can be compensated when heating is required. Its built-in air deflection device enables to offset the buoyancy forces: with the damper closed (Fig. 4, Heating), the outlet generates a radial downflow which counters the buoyancy forces of the warm supply air that can thus penetrate deep into the room.

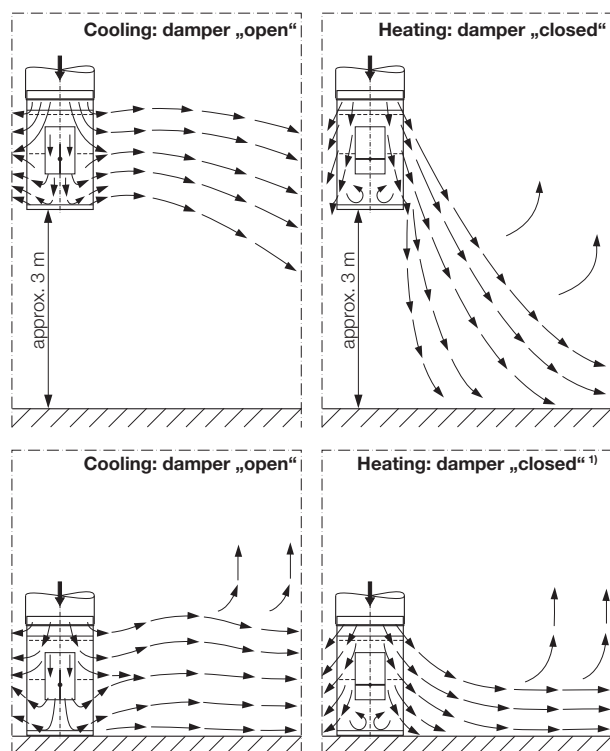

Fig. 4: Air jet dispersion
top: with outlet above the occupied zone
bottom: with outlet on the floor

¹⁾ See 'Selection and layout' on page 5



Fig. 5: Air jet dispersion made visible by smoke tracer
top: cooling mode
bottom: heating mode

Air flow geared to requirements

The above description of air jet dispersion when cooling and heating relates to damper settings 'open' and 'closed' respectively. In practical operation, however, the supply air is usually introduced into the space at various intermediate settings of the damper, depending on the prevailing cooling load.

Circular displacement outlet VA-ZD

Selection and layout

The damper being steplessly adjustable, it allows to gear the direction of the supply air jets to the cooling or heating requirements and thus to achieve an efficient and uniform air flow within the occupied zone. This enhances the thermal comfort of the occupants and in most cases obviates the need for an extra heating device in winter.

As the circular displacement outlet is able to discharge the whole supply air vertically downwards, it is eminently suited for accelerating the heating up of the space concerned, e.g. after a prolonged interruption in operation. This ability can also be used to flush the occupied zone with more fresh air prior to start of work or during breaks.

Selection and layout

The circular displacement outlet with adjustable damper can be used in all fields of trade and industry. Whether it will be placed above the occupied zone or on the floor depends on both the type of pollutants to be extracted and the amount of specific heat gains.

Industrial applications require specific supply air flow rates of 4 to 28 l/(s · m²) [15 to 100 m³/(h · m²)] or more, depending on the production process. This broad range can be achieved by selecting the appropriate number and size of air outlets with the related air flow rates as well as the most suitable placement (anywhere in the space or in front of a wall or pillar).

We recommend to select, as far as possible, an air flow rate within the upper range (see graphs on pages 6 and 7 as well as table in Figure 1) if

- a great difference in temperature between supply air and indoor air ¹⁾ is required for heating the space and
- a large supply air penetration depth is required.

For outlet placement above the occupied zone a distinction is made between the primary penetration depth and the maximum supply air penetration depth (Fig. 6). In the cooling mode the primary penetration depth denotes the furthest point from the air outlet at which the entire supply air has entered the occupied zone. In the heating mode it denotes the point at which the first portions of supply air begin to move upwards. The maximum supply air penetration depth is shown in the graphs on page 6. The primary penetration depth is about one third shorter.

For placement at about 3 m above the occupied zone we recommend a maximum temperature difference of ±10 K between supply air and indoor air.

¹⁾ We recommend measuring the indoor air temperature in the occupied zone, for control purposes

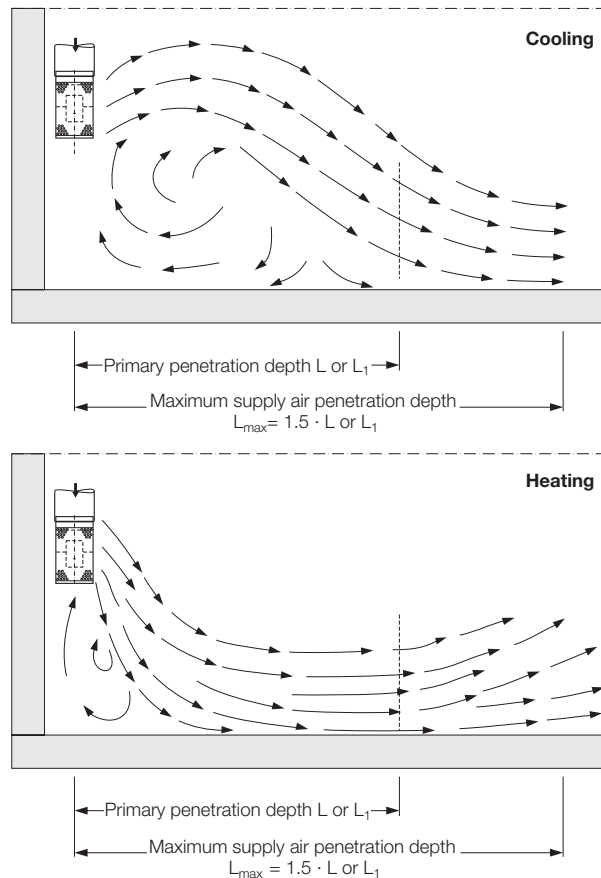

Fig. 6: Primary penetration depth and maximum supply air penetration depth for outlet placed above the occupied zone

In case of outlet placement on the floor the maximum supply air penetration depth when cooling depends only on the number and intensity of heat sources. For the cooling mode we recommend a minimum supply air temperature of 18 °C and for the heating mode a maximum temperature difference of 10 K between supply air and indoor air.

When heating, the horizontal penetration depth of the supply air depends not only on its volume flow rate and temperature, but also on the prevailing indoor conditions. The optimum penetration depth can be set by adjusting the damper **6**.

The outlet layout will be made using the graphs that follow.

Circular displacement outlet VA-ZD

Layout sheet for placement at about 3 m above the occupied zone

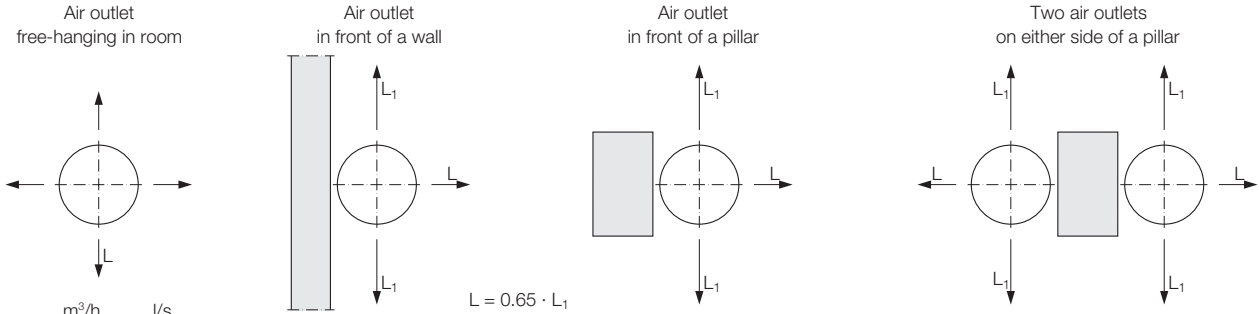

$$L = 0.65 \cdot L_1$$

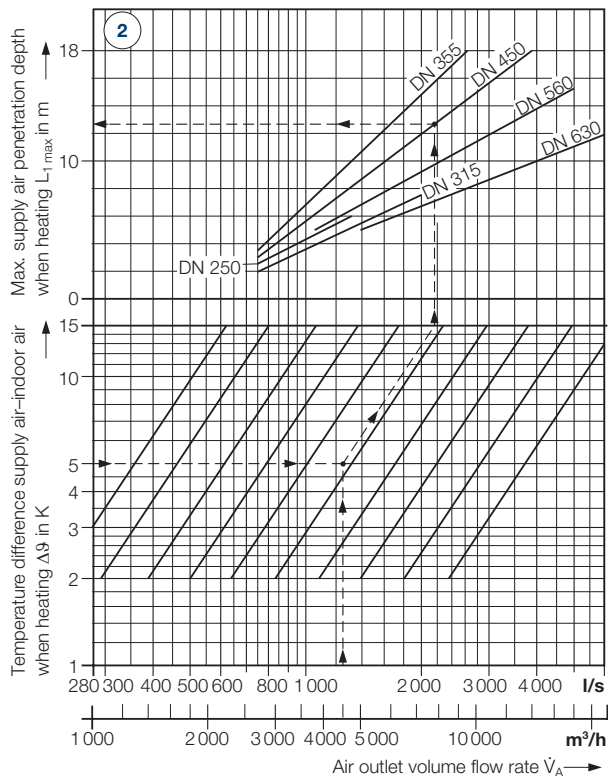
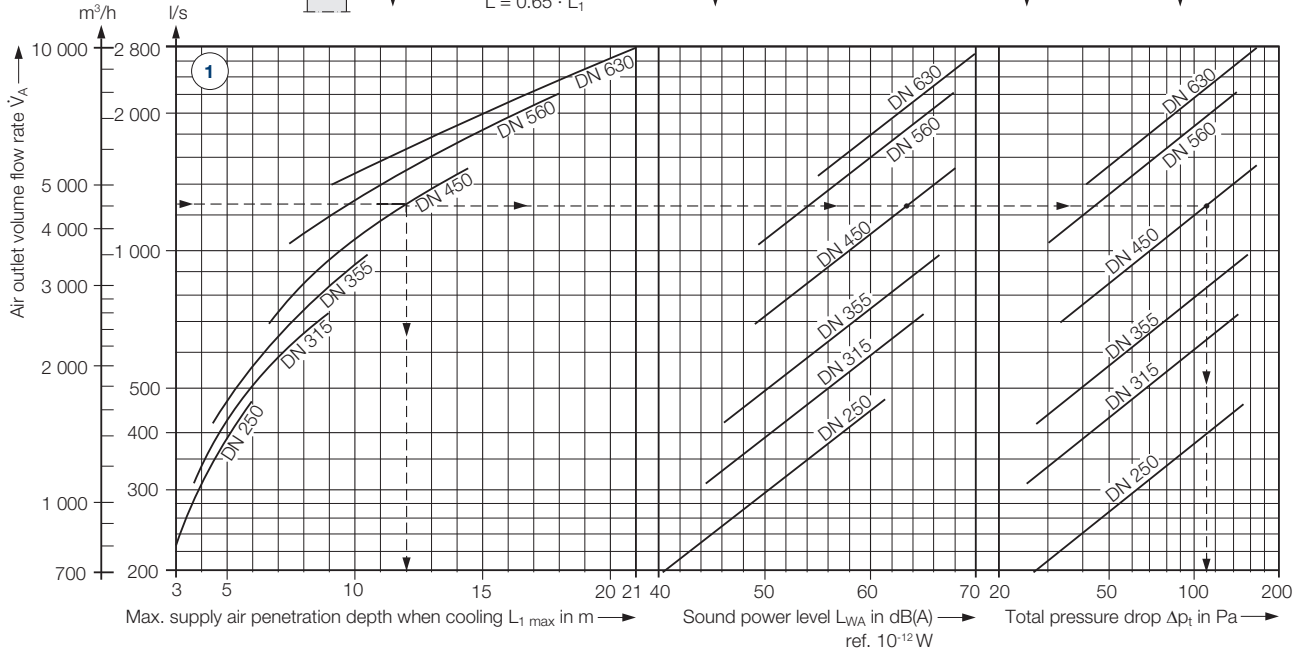

Outlet size \varnothing DN	Min. volume flow rate for placement			
	at 3 m height $\dot{V}_{A\min}$		on the floor $\dot{V}_{A\min}$	
	l/s	m³/h	l/s	m³/h
250	195	700	140	500
315	305	1 100	220	800
355	415	1 500	305	1 100
450	695	2 500	485	1 750
560	1 055	3 800	750	2 700
630	1 400	5 000	970	3 500

Layout example:

Placement at 3 m above the occupied zone, in front of a pillar

- Air outlet volume flow rate $\dot{V}_A = 1 250$ l/s [4 500 m³/h]
- Required supply air penetration depth $L_1 = 11$ m
- Temperature difference
supply air-indoor air $\Delta\theta = +5$ K when heating
- Maximum allowable sound power level $L_{WA} = 65$ dB(A) ref. 10^{-12} W

From graph 1:

- Outlet size = DN 450
- Max. supply air penetration depth $L_{1\max} = 12$ m (when cooling)
- $L_{WA} = 63$ dB(A) ref. 10^{-12} W
- $\Delta p_t = 110$ Pa

From graph 2:

- Max. supply air penetration depth $L_{1\max} \approx 12.5$ m (when heating)

Circular displacement outlet VA-ZD

Layout sheet for placement on the floor

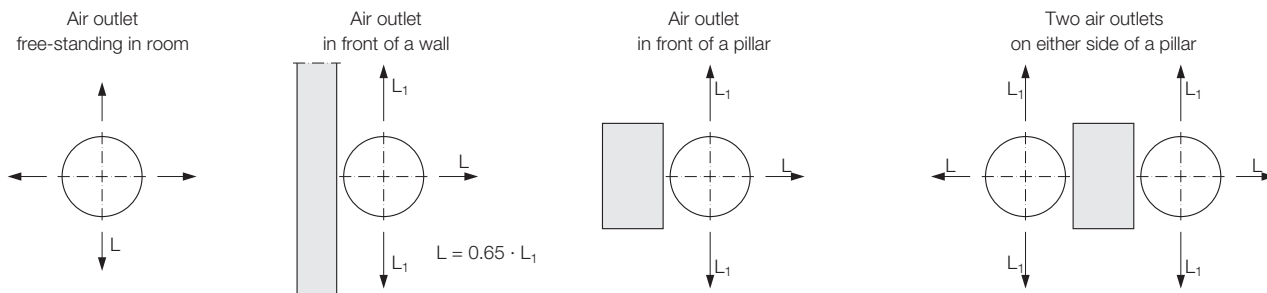

Note:
The maximum supply air penetration depth when cooling largely depends only on the number and intensity of heat sources. Under normal conditions the maximum supply air penetration depth is $L_{1\max} = 10\text{ m}$ with size DN 250 and $L_{1\max} = 25\text{ m}$ with size DN 630.

These figures apply for the respective maximum volume flow rates. With specific heat loads over 120 W/m^2 the above maximum supply air penetration depths must be reduced by 30%.

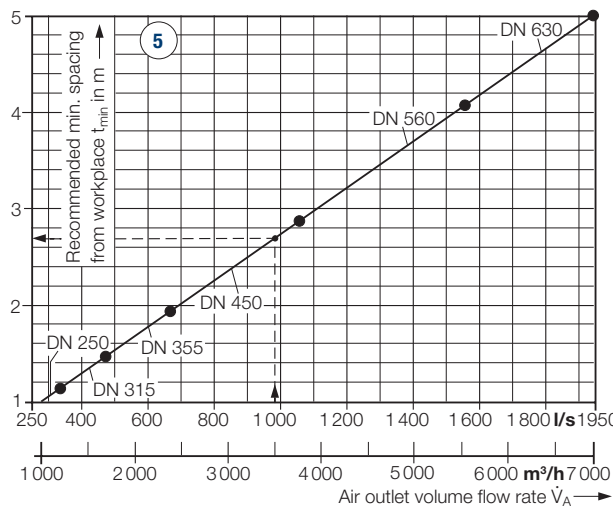
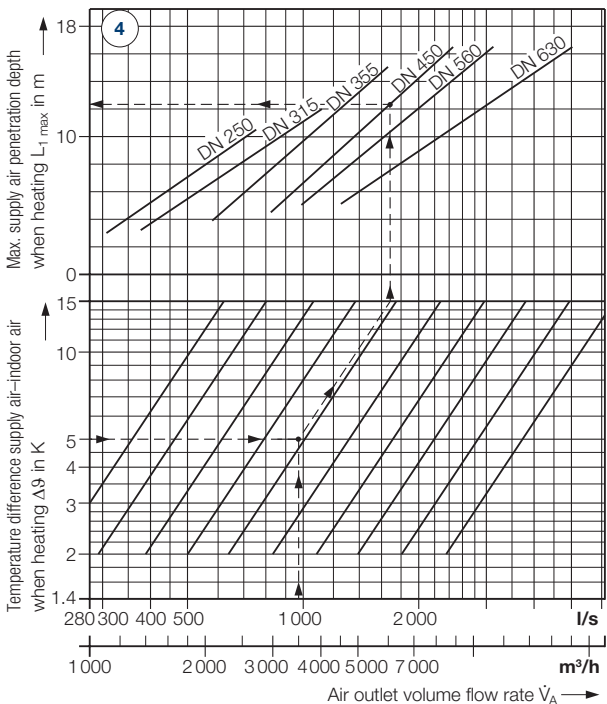
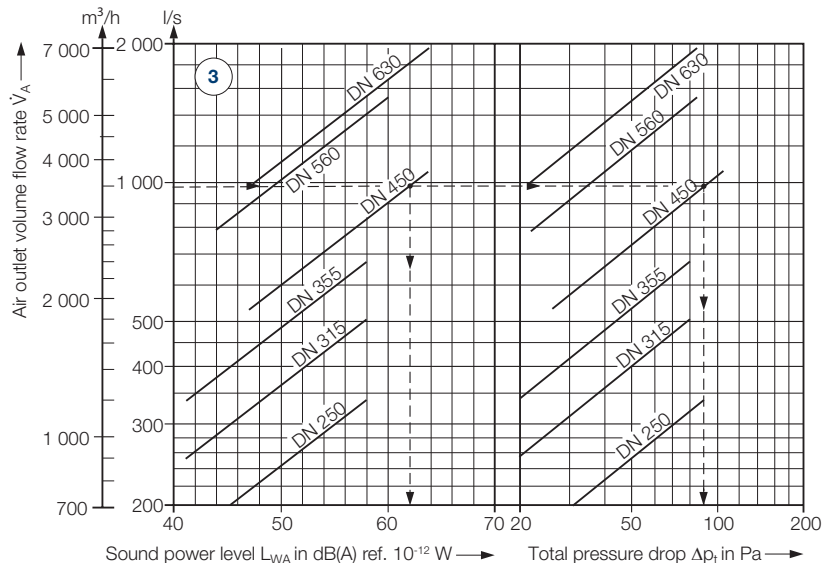

www.krantz.de_DS_4059_E_p.7_04.2018

Layout example:

Placement on the floor, in front of a wall

- 1 Air outlet volume flow rate $\dot{V}_A = 975\text{ l/s}$ [3,500 m³/h]
- 2 Required supply air penetration depth $L_1 = 9\text{ m}$
- 3 Temperature difference supply air-indoor air $\Delta\theta = +5\text{ K}$ when heating
- 4 Maximum allowable sound power level $L_{WA} = 65\text{ dB(A)}$ ref. 10^{-12} W

- From graph 3:**
- 5 Outlet size = DN 450
- 6 $L_{WA} = 62\text{ dB(A)}$ ref. 10^{-12} W
- 7 $\Delta p_t = 90\text{ Pa}$

- From graph 4:**
- 8 Max. supply air penetration depth $L_{1\max} \approx 12\text{ m}$ (when heating)

- From graph 5:**
- 9 $t_{\min} = 2.7\text{ m}$

Circular displacement outlet VA-ZD

Altering the air discharge direction

Altering the air discharge direction

The air discharge direction will be altered by the adjustment of the built-in damper either manually or via an electric actuator or a thermal control unit.

Manual adjustment

a) with a **Bowden cable** which is linked to a control lever fixed to a support for wall or pillar mounting and enables the stepless setting of different air discharge directions (Fig. 8).

b) with a **chain pull** which hangs down through the outlet bottom and enables to open or close the damper. In the cooling mode the damper is open, with the chain being uplifted by about 150 mm by a tension spring. To close the damper when heating, the chain must be pulled down. To stop the chain and thus set the damper position, chain links must be jammed in the keyhole aperture in the outlet bottom.

Visible chain length: $L_{cooling\ to\ heating} = 1\ 000\ to\ 1\ 150\ mm$

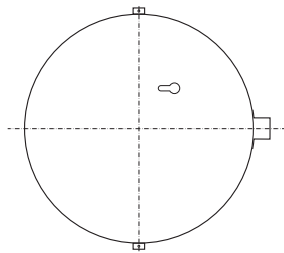
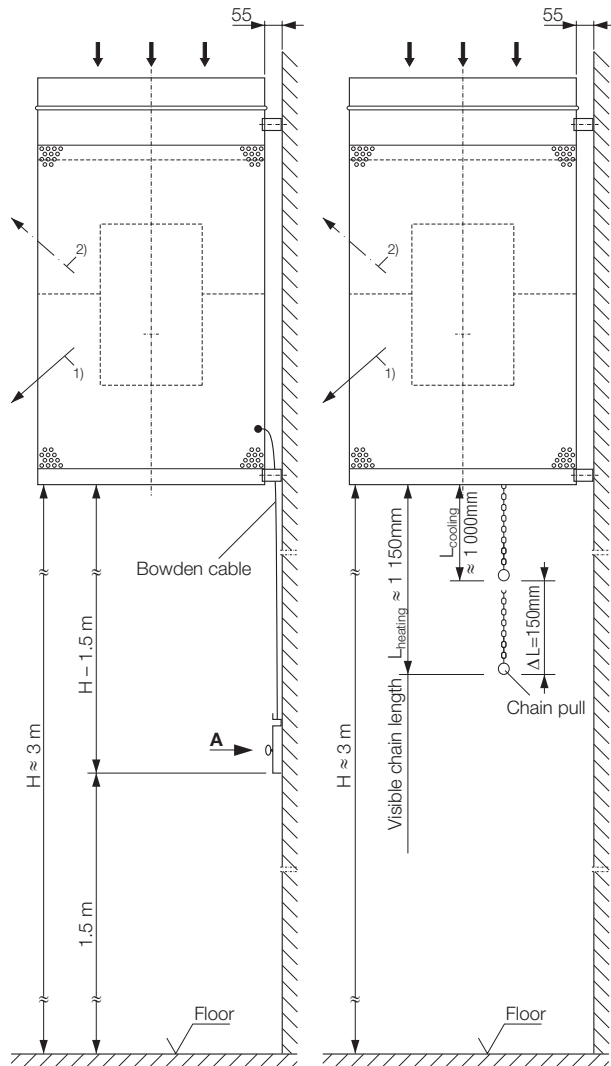

Fig. 7: Keyhole aperture in outlet bottom for passage and stoppage of chain pull

Adjustment with Bowden cable or chain pull is to be preferred for outlet placement in front of a wall or pillar (Fig. 8).

c) with a **control lever** positioned on the perforated cylinder. The control lever setting indicates the air discharge direction (Fig. 9).

This adjustment system is often used for outlets placed on the floor. Yet it can also be used for outlets placed above the occupied zone if damper adjustment is required only seldom.



View A: Support with control lever

Control lever to the left: The supply air is discharged at an upward incline: cooling mode

Control lever to the right: The supply air is discharged steeply downwards: heating mode

Intermediate settings of the control lever enable to adjust the direction of the supply air jets to the prevailing thermal loads.

- 1) Heating (damper **closed**)
- 2) Cooling (damper **open**)

Fig. 8: Manual alteration of discharge direction via
 – Bowden cable, top left and bottom
 – chain pull, top right

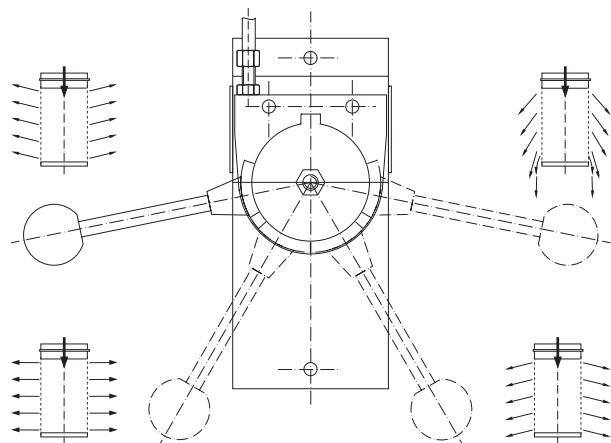

Circular displacement outlet VA-ZD

Altering the air discharge direction

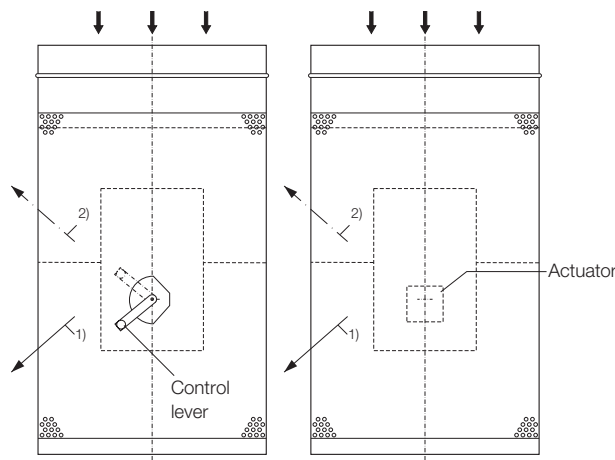

Fig. 9: Alteration of discharge direction
left: manually, via control lever
right: automatically, via electric actuator

Adjustment by electric actuator

The actuator is lodged inside the outlet housing, against the air deflection tube. Its power cord runs through the perforated cylinder. This type of adjustment is best suited if the client requires the automatic alteration of the discharge direction in relation to the temperature difference between the supply and indoor air, or a centrally controlled heating-up process, or forced controls, or in case several outlets are to be adjusted simultaneously.

Adjustment by thermal control unit

With the thermal control unit the adjustable damper, and with it the air discharge direction, is self-adjusted – without auxiliary energy – in response to the temperature difference between the supply and indoor air. This unit controls the heating and cooling modes most efficiently.

Depending on the temperature difference between the supply air and the indoor air, or simply depending on the supply air temperature, a piston stroke is created and transmitted via a rod assembly to the damper. The damper angle α controls the air discharge direction. If α is

- large, the supply air is discharged at a slight upward angle;
- small, the supply air is discharged steeply downwards.

Krantz offers two variants of the thermal control unit.

The TS control unit operates purely via the supply air temperature (sensor **8a** in Fig. 12). The TD control unit regulates as a function of the temperature difference between supply air and indoor air (sensors **8a** and **8b** in Fig. 10).

Examples of application:

1. Assembly hall with a room temperature of 16 °C and a supply air temperature of 22 °C.

The example requires heating with a downward discharge direction. The TS control unit, working only through regulating the supply air temperature, would blow out supply air roughly horizontally and is therefore not suitable. Here the TD control unit would be more appropriate.

2. Foundry with a room temperature of 30 °C and a supply air temperature of 22 °C.
 The example requires cooling with a discharge direction pointed slightly upward. Both control units can be deployed.

Design and mode of operation (TD variant)

The main component is a wax-expansion thermostatic element **8**, positioned at the intake spigot of the circular displacement outlet and with a temperature sensor in both the supply air **8a** and indoor air **8b** (Fig. 10).

In the preset basic setting of the thermal control unit, the damper control range is $\alpha = 90$ to 35° .

This basic setting is normally sufficient for room temperatures t_R of 14 to 28 °C. The air discharge direction varies according to the damper angle, for example,

- from $\alpha = 90^\circ \Rightarrow$ slight upward incline
- to $\alpha = 35^\circ \Rightarrow$ steep downward flow.

How to change the basic setting

In some few applications it may be useful to change the direction of the supply air jets beyond the basic setting. If circular displacement outlets are used, for instance, in industrial halls with all-year high room temperatures, a supply air stream being directed more downwards is likely to increase the fresh air effect. On the other hand, in the cooling mode, in spaces with all-year low room temperatures, the thermal comfort of the individual occupants can be enhanced by directing the supply air stream more upwards. It is also possible to select different air discharge directions for individual outlets depending on the areas where they are located, e.g. flatter above occupied zones and steeper downwards above gangways.

For such cases the setting for the thermal control unit can be altered from the outside at the damper angle setting plate **10**. The damper angle setting can be altered by $\pm 20^\circ$.

Example 1: All-year room temperature $t_R \geq 28^\circ\text{C}$; if there is a need for more air movement within the space, the air discharge must occur steeper downwards for increased fresh air effect \rightarrow adjustment towards the red mark.

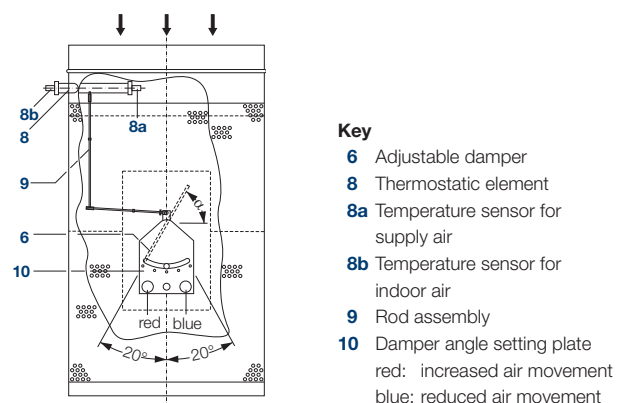

Fig. 10: Circular displacement outlet with integrated thermal control unit in basic setting, position 0
Variant TD \rightarrow Thermal control unit, supply air–indoor air

Example 2: All-year room temperature $t_R < 20^\circ\text{C}$; if there is a need for less air movement within the space, the air discharge must occur at a slightly greater upward incline and the total supply air stream will get flatter \rightarrow adjustment towards the blue mark.

Circular displacement outlet VA-ZD

Volume flow rate setting and outlet fastening

The following graph (Fig. 11) shows the damper angle for different settings, in response to the temperature difference between the supply and indoor air, and the resulting air discharge directions. Due to hysteresis the actual damper angle may differ by about 5° from the theoretical value.

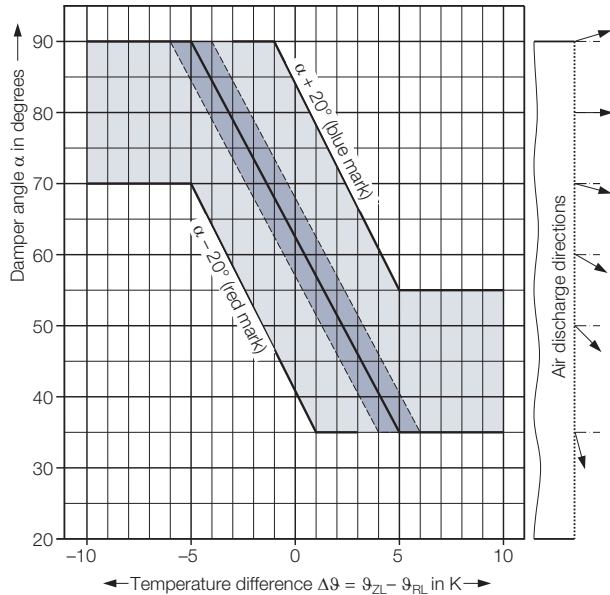

Fig. 11: Damper angle α in response to the temperature difference between the supply and indoor air, and resulting air discharge directions (TD variant)

Design and mode of operation (TS variant)

With the TS variant, the air outlet direction is adjusted only on the basis of the supply air temperature. The wax-expansion thermostatic element **8** is located on the interior of the air outlet (Figure 12). The damper angle and resultant air outlet direction as a function of supply air temperature are shown in Figure 13. The TS variant also has the option of retrospectively adapting the factory-set basic setting to local conditions, as required.

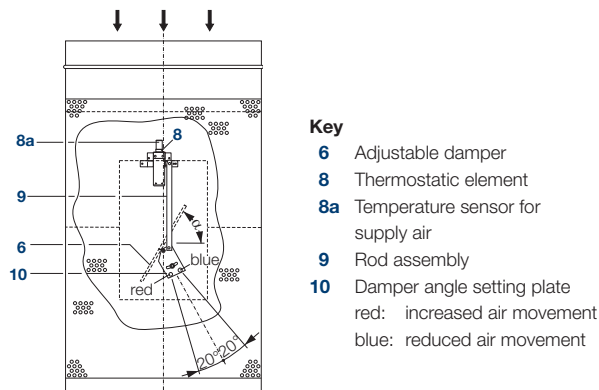

Fig. 12: Circular displacement outlet with integrated thermal control unit in basic setting, position 0
TS variant → thermal adjustment unit, supply air

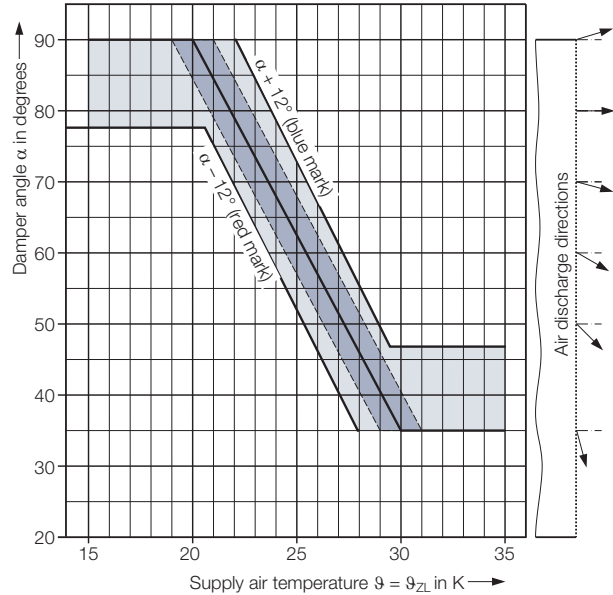

Fig. 13: Damper angle α as a function of supply air temperature and the corresponding air discharge direction (TS variant)

Volume flow rate setting

In general, the volume flow rate setting for several VA-ZD outlets fed by the same ductwork occurs via volume flow rate throttle devices to be provided by the client. As a rule, these throttle devices are positioned immediately upstream of the air outlets. For such cases Krantz supplies, on request, specially designed volume flow dampers to be fitted onto the VA-ZD outlets, on the air intake side. Their advantages are:

- no impairment of air flow pattern,
- no further pressure drop and no increase in sound power level when the damper is open.

When the volume flow damper is closed, the pressure drop can be 2.5 times as high as it is in the open position. This increases the sound power level by approx. 4 dB(A) ref. 10^{-12} W.



Fig. 14: Circular displacement outlet positioned on the floor

Circular displacement outlet VA-ZD

Features

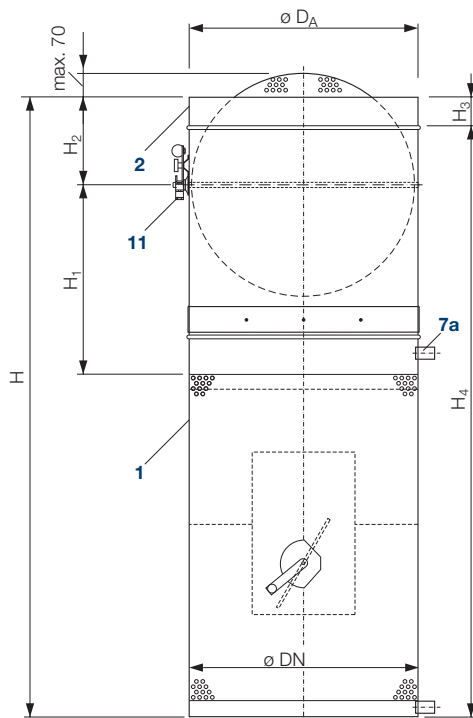

Key

- 1** Perforated cylinder
- 2** Connection spigot
- 7a** Fastener
- 11** Adjusting device for volume flow damper

Size	ø D _A mm	H mm	H ₁ mm	H ₂ mm	H ₃ mm	H ₄ mm
DN 250	249	1250	430	100	60	1 190
DN 315	314	1250	430	100	60	1 190
DN 355	354	1500	460	120	80	1 420
DN 450	449	1550	465	165	80	1 470
DN 560	559	1660	520	220	80	1 580
DN 630	629	1720	545	255	80	1 640

Fig. 15: Volume flow damper fitted to the intake side of the circular displacement outlet

Air outlet fastening

a) Placement above the occupied zone

In this placement option the air outlet is frequently mounted on a wall or pillar, using two fasteners **7a** with boreholes ø 11 mm positioned at the top and bottom of the outlet housing. For fastening, the client will insert screws of type M10, for instance, into brick-work anchors having the same size.

If the outlet is freely suspended, fastening can be done, for example, by riveting or bolting to the round air duct. Further, suspension from the ceiling can be done with two opposite L-fasteners **7b** positioned on the air intake side and designed for fastening threaded rods or similar fixtures.

b) Placement on the floor

In this placement option the air outlet is set up either directly on the floor or on a base having a maximum height of 0.5 m. It will be fixed using the available fasteners **7a** (if standing against a wall or pillar) or it will be fastened to the floor using brackets to be provided by the client.

Cost-effective control

With the exception of forced control¹⁾, the thermal control unit offers the same control options as, for instance, an electric temperature difference control device. It also enables various settings for different room control zones.

This control system obviates the need for electric actuators inside the air outlets, wiring, controllers, and switch cabinet with power supply unit; this means no additional energy costs.

Controlling with thermal control units is much cheaper than with actuators, especially in the case of reconfiguration of the space and/or rearrangement of the outlets concerned.

Features

- Low-turbulence radial displacement flow
- High fresh air quality in the occupied zone
- Placement above the occupied zone or, with finely perforated cylinder, on the floor
- Stepless alteration of air discharge direction thanks to built-in adjustable damper, thus well suited for cooling and heating
- Adjustment options: manual, by electric actuator, or by thermal control unit
- Rapid decrease in radial jet velocity
- Primary penetration depth of supply air jets: up to approx. 14 m; maximum supply air penetration depth: approx. 20 m
- Max. temperature difference supply air–indoor air
 - with placement above the occupied zone: $\Delta\theta = \pm 10$ K when heating or cooling
 - with placement on the floor: $\Delta\theta = +10$ K when heating, minimum supply air temperature: 18°C when cooling
- Volume flow rate range: 194 to 2 800 l/s [700 to 10 000 m³/h]
- 6 sizes available: DN 250 to DN 630
- Option: volume flow damper for even air supply to several displacement outlets connected to the same ductwork
- Made of galvanized sheet metal
- For connection to ducts to EN 1506
- Robust construction with only few adjustable parts



Fig. 16: Circular displacement outlets in car manufacturing halls

¹⁾ e.g. to accelerate heating up

Circular displacement outlet VA-ZD

Type code and tender text

Type code

VA-ZD - - - DN - - - - -



Mounting

- A = 3 m above the occupied zone
- B = placement on floor

Size

- 250 = DN 250
- 315 = DN 315
- 355 = DN 355
- 450 = DN 450
- 560 = DN 560
- 630 = DN 630

Adjustment

- E4 = „Belimo actuator, 0–10 V modulation“, rotation drive type LM24A-SR
- B = Bowden cable
- K = chain pull
- S = control lever
- TD = temperature difference regulator
- TS = supply air regulator

Damper

- O = no volume flow damper
- V = with volume flow damper

Surface finish

- galv = galvanized
- 9006 = face painted to RAL 9006, semi-matt
- = face painted to RAL

Accessories

- O = none
- H = fasteners for wall mounting
- W = L-fasteners for suspension

Tender text

..... units

Circular displacement outlet generating a low-turbulence supply air flow and minimal mixing of supply air with indoor air for optimum displacement of airborne particles and pollutants from the occupied zone,

consisting of:

- a perforated cylinder with connection spigot and plain bottom, and a built-in air guiding device with orifice rings, an air deflection tube and an adjustable damper for adapting the air discharge direction to varying internal thermal loads when heating and cooling.
- Adjustment of air discharge direction either manually – with Bowden cable ¹⁾, chain pull ¹⁾ or control lever on perforated cylinder – or by electric actuator or by built-in thermal control unit for automatic damper adjustment.

The TS control unit adjusts the damper solely through the supply air.

In applications with widely fluctuating room temperatures, the TD control unit is applied. The air outlet direction is thus controlled as a function of the temperature difference between supply air and indoor air.

The piston stroke is transmitted via a rod assembly. The factory setting of the supply air control damper can be subsequently customized to local requirements through the damper settings plate.

The outlet will be either suspended above the occupied zone or placed on the floor (cylinder with finer perforations). It will be optionally fitted with fasteners for wall or pillar mounting or with two opposite L-fasteners (on the air intake side) for suspension with threaded rods or similar fixtures.

- Option: volume flow damper with perforated blade, specially designed for the circular displacement outlet, for even air supply to several outlets connected to the same ductwork, with round casing and adapter sleeve for fitting onto the outlet housing (air intake side) and with external adjusting device.

Material:

- Air outlet made of galv. sheet metal ²⁾, visible outlet parts optionally painted to RAL

Make:

Krantz

Type:

VA-ZD - - - DN - - - - -

Subject to technical alterations.

¹⁾ For placement at 3 m above the occupied zone; any other discharge height is to be specified in the related enquiry and/or order

²⁾ Stainless steel upon request

Krantz GmbH

Uersfeld 24, 52072 Aachen, Germany

Phone: +49 241 441-1

Fax: +49 241 441-555

info@krantz.de | www.krantz.de

