

DS 4136 E 10.2022

# Air & Climate Solutions

## Opticlean

### OC-Q



# Opticlean

## Features, scope and field of application, aerotechnical function

### Features

The Opticlean OC-Q by Krantz meets all important requirements for a supply air ceiling diffuser for diffused room air flow:

- High thermal comfort
- Discrete integration into the suspended ceiling
- Low ceiling pollution
- Low sound power level and pressure drop

### Scope of application

The Opticlean by Krantz is suitable for installation in suspended ceiling systems.

The standard version is compatible with grid ceilings with a grid size of 625 x 625 mm or 600 x 600 mm. The Opticlean is placed on the T-profiles of the ceiling system instead of a ceiling tile and connected to the supply air duct.

For installation in gypsum plasterboard ceilings (GK ceilings), there are square standard versions in sizes 215, 270, 330, 400, 500, 600 as well as a round version (OC-R).

The faceplate of the front panel is perforated as standard with the diagonally offset round perforation Rd 2820. The hole diameter is 2.8 mm, the pitch 5.5 mm. The Rd2820 hole pattern corresponds to the typical appearance of common metal ceiling panels for ceiling systems.

With the same perforation pattern, the Opticlean is indistinguishable from the normal ceiling tile. It is also possible to combine the Opticlean with different perforations. This requires technical clarification with our specialists.

### Field of application

- Room heights 2.5 to 4.5 m
- Maximum temperature difference supply air-room air
  - $\pm 10$  K up to 3 m room height
  - $\pm 5$  K up to 4,5 m room height
- Volume flow rate range from 40 to 860 m<sup>3</sup>/h
- Can also be used as exhaust air intake

### Aerotechnical function

The supply air flows very evenly through the perforated faceplate and spreads radially in a horizontal direction. By induction of room air, the flow velocity and the temperature difference between supply air and room air are rapidly reduced. This results in a pleasant indoor climate with low room air velocities and uniform room air temperatures in the occupied zone.

Unlike inductive ceiling diffusers, the induced room air does not touch the perforated visible surface. An air cushion forms under the OC-Q, which greatly reduces the ceiling pollution that occurs.

If the Opticlean is installed near a wall or in the corner of a room, the discharge direction can be adjusted using appropriate covers to prevent drafts in the occupied area.

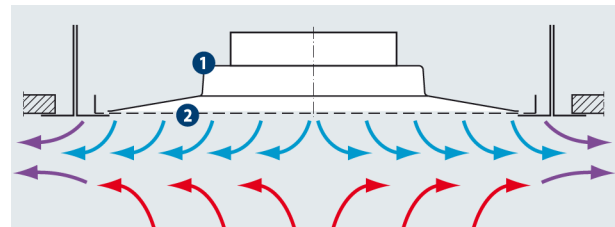

Fig. 1: Flow pattern of the Opticlean



Fig. 2: Flow pattern of the Opticlean made visible by smoke

### Sizes and performance

Seven Opticlean sizes are available depending on the room, ventilation requirements and cassette format. Each size has been tested by Krantz with eight different perforations and compatibility was confirmed.

### Constructional design

#### Caption

- |                             |                         |
|-----------------------------|-------------------------|
| 1 Air distribution element  | 5 Volume flow damper    |
| 2 Perforated faceplate      | 6 Acoustic fleece       |
| 3 Connection box            | 7 Gypsum mounting frame |
| 3a Connection box, standard | 8 Drywall screw         |
| 3b Connection box, flat     | 9 Spacer                |
| 4 Connection spigot         |                         |

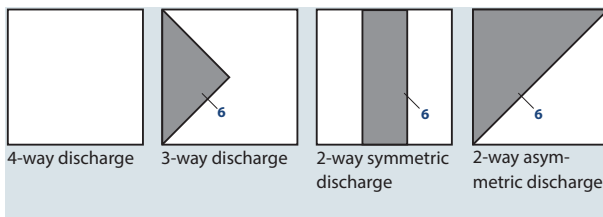

Fig. 3: Change of discharge direction by covers made of acoustic fleece

#### Comments Table 1

If the minimum supply air volume is not reached, the OC-Q can be equipped with an optional flow stabilizer. The flow stabilizer maintains the aerodynamic function of the OC-Q. The flow stabilizer is available for sizes 215, 270 and 330.

Table 1: Dimensions

Nominal size	Supply air volume flow rate		Grid size mm	□E mm	□E <sub>1</sub> mm	ø D mm	L <sub>1</sub> mm	0			K			F	
	l/s	m <sup>3</sup> /h						H <sub>1</sub> <sup>1)</sup> mm	H <sub>2</sub> mm	H <sub>s</sub> mm	L mm	B mm	H <sub>3</sub> mm	H <sub>s</sub> mm	
215	11-30	40-110	600x600 625x625	595 620	214	79	40	190	—	—	—	212	160	105	
270	18-47	65-170			265	99	40	220	200	137,5	165	263	182	115	
330	28-69	100-250			321	124	40	260	230	155,2	190	319	207	127,5	
400	36-119	130-430			391	159	40	320	280	187,7	225	389	242	145	
500	50-161	180-580			491	199	40	390	325	213	265	489	282	165	
600	75-238	270-860	600x600	595	591	249	60	500	410	273	315	589	332	190	
625	75-238	270-860	625x625	620	616	249	60	500	410	273	315	614	332	190	

<sup>1)</sup> The total height is based on a minimum bending radius of R/D = 0.5. Depending on the type of hose used, smaller bending radii are also possible.

### Dimensions

#### Connection type 0

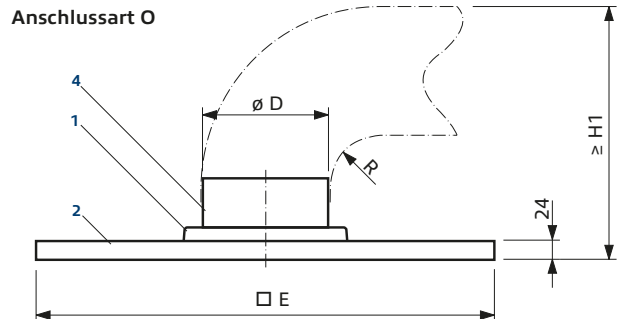

#### Connection type K

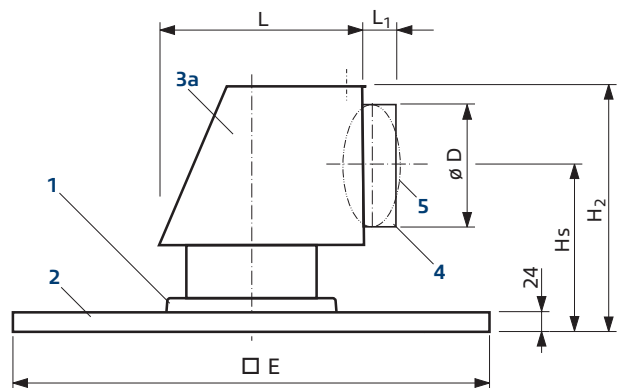

#### Connection type F

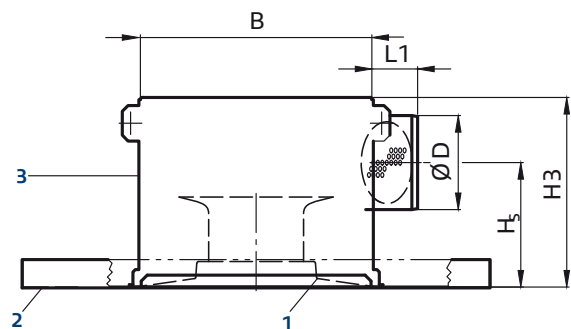

Fig. 4: Connection types Opticlean

# Opticlean

## Gypsum plasterboard ceilings - design QG

For installation in a gypsum plasterboard ceiling, the faceplate is folded outwards on two opposite sides and placed on the gypsum plasterboard installation frame **7**. The gypsum plasterboard installation frame is previously inserted from above into the ceiling cut-out and fastened with four drywall screws **8** TN 3.5 x 25 (on-site). The joint between the frame and the gypsum plasterboard panel is filled by the customer and later painted in the desired color together with the ceiling.

The front panel is centered by eight spacers **9**. This creates a uniform joint between the gypsum plasterboard mounting frame and the front panel. This design is intended for 12.5 mm thick gypsum panels as standard. Gypsum plasterboard mounting frames for other panel thicknesses on request.



Fig. 7: Opticlean installed in a gypsum plasterboard ceiling

### Detail of mounting frame

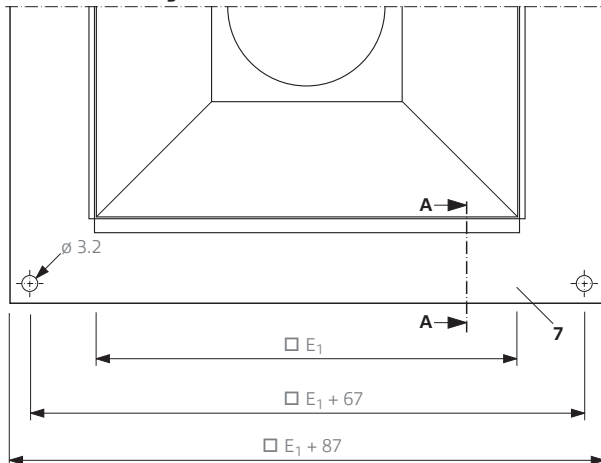

### Section A-A

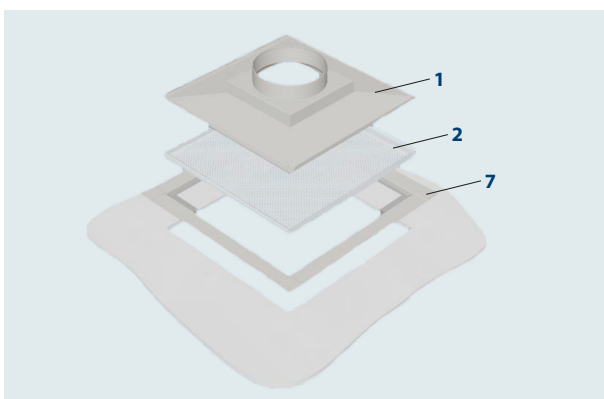
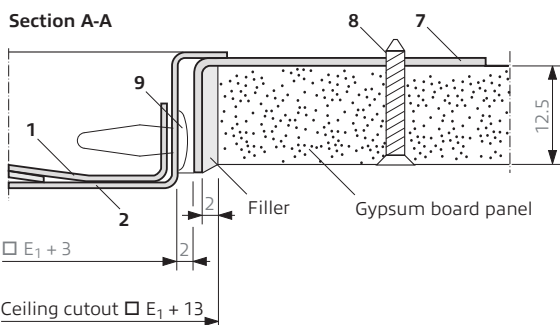

Fig. 5: Detail OC-Q gypsum plasterboard ceiling installation frame



Fig. 8: Opticlean installed in a perforated gypsum plasterboard ceiling

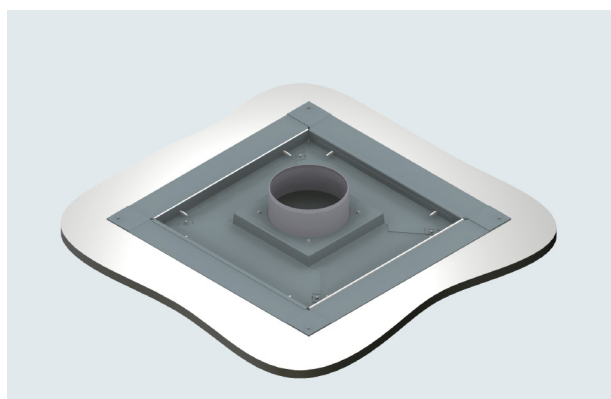

Fig. 9: Opticlean with gypsum plasterboard ceiling mounting frame

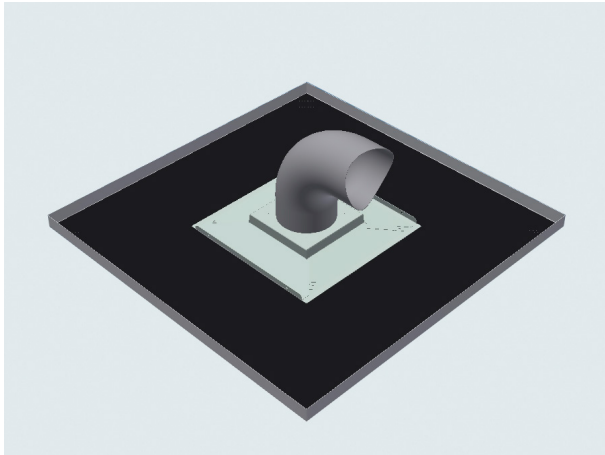

Fig. 10: Opticlean for tube connection or 90° tube bend

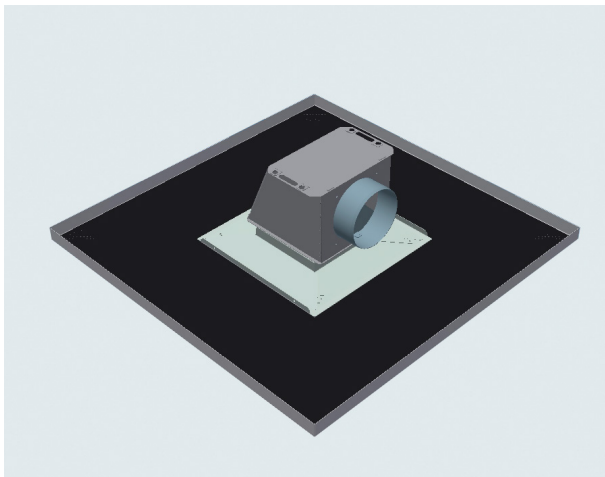

Fig. 11: Opticlean with connection box K

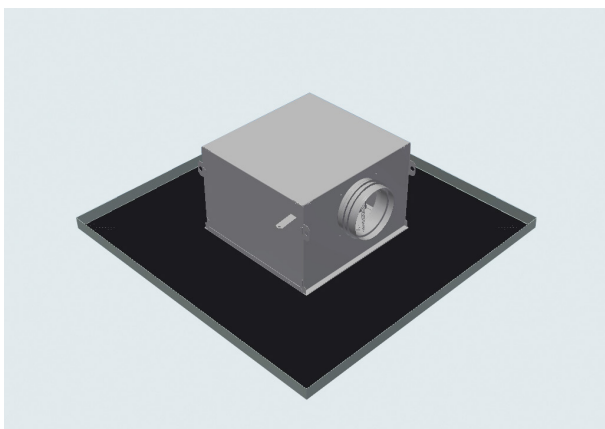

Fig. 12: Opticlean with flat plenum box F

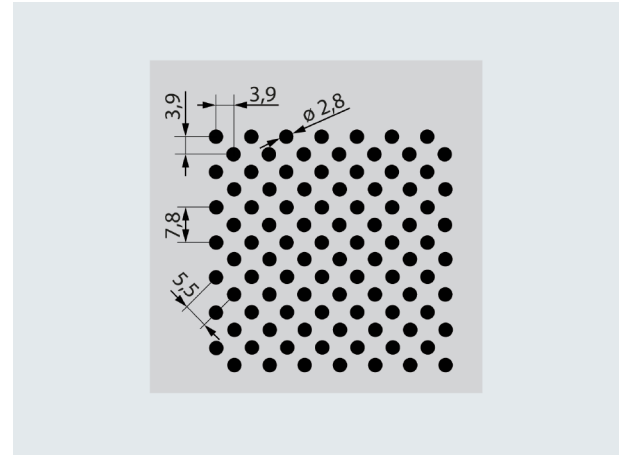

Fig. 13: Standard ceiling tile type 2820  $\varnothing$  2.8 mm;  
hole percentage 20 %; Rd 2.8 - 5.5 (n. DIN 24041)

### Exhaust air diffusers

The Opticlean is designed for supply air operation. Use as an exhaust air inlet is also possible, but cancels the protection of the diffuser against pollution. This is especially true when installed in rooms with increased particle pollution (e.g. passageways, smoking areas, etc.).

### Connection types

Connection to the duct system is possible by means of

- Tube connection or 90° pipe bend (Fig. 10)
- Plenum box K (Fig. 11) recommended if a flow damper is required.
- Plenum box F (Fig. 12), recommended if false ceiling height is low

The Opticlean is designed as standard for use with ceiling panels with a sheet thickness of 0.6 mm (without powder coating or painting) and a diagonally offset round perforation with a hole diameter of 2.8 mm, pitch 5.5 mm. The Opticlean is optimized in its ventilation function for use with these ceiling tiles. In general, it is possible to use the Opticlean on other ceiling tiles, but this may result in different aerodynamic or acoustic data. As a general rule, use on ceiling tiles thicker than 0.75 mm and with hole diameters of less than 2 mm should be avoided. In these cases, we recommend a technical consultation with our specialists.

Adapted solutions are available for most common metal ceiling tiles. Technical data available on request.

# Opticlean

## Notes for planning

### Minimum air diffuser center distance

When planning, take into account the specified minimum distances (**diagram 2**). If you plan the Opticlean close to a wall, use half the distance.

If it is not possible to maintain the minimum distances for structural reasons, then the air outlets can be provided with additional covers (**Fig. 15**).

This reduces the air flow rate accordingly by 25 % or 50 %.

A special case is when the minimum distance in the room is not reached. As long as the diffusers are half the minimum distance apart, the ventilation function of the OC-Q can be ensured by a cover (**Fig. 14**).

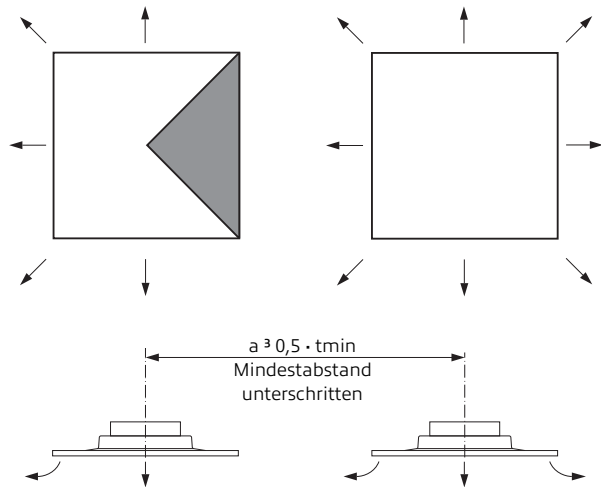

Fig. 14: Arrangement of the cover when the minimum distance is not reached

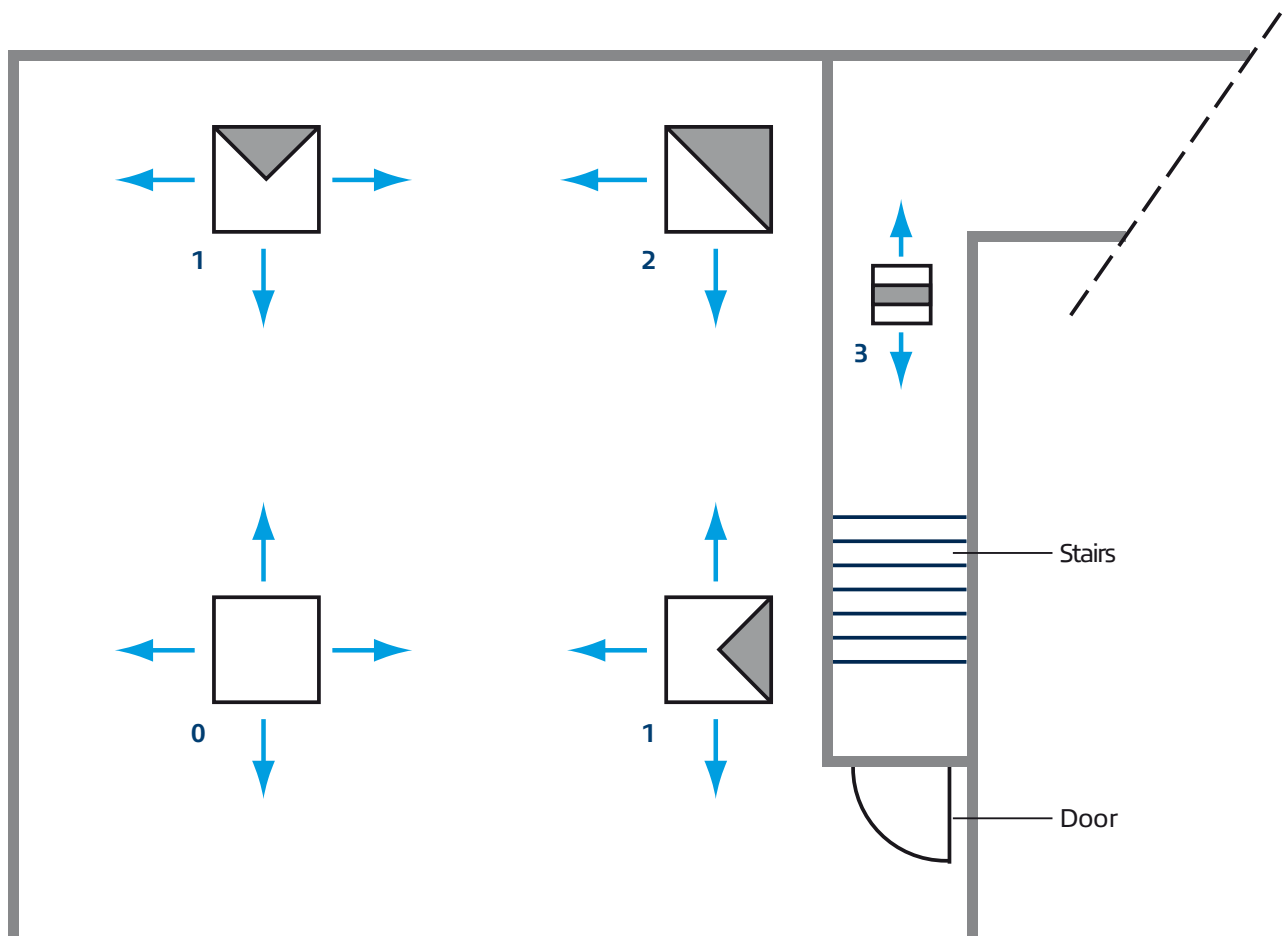

Fig. 15: Principle sketch Opticlean with covers for adjusting the discharge direction

### Caption

- 0 Without covers
- 1 3-sided discharge
- 2 2-sided asymmetric discharge
- 3 2-sided symmetrical discharge

### Comfort criteria

The design of the Opticlean is based on maintaining the permissible room air velocity  $u$  in cooling mode. The room air velocity depends on the required cooling load. The maximum specific cooling capacity  $q$  depends on the discharge height and the maximum permitted room air velocity  $u$  (**Diagram 1**).

The maximum specific volume flow  $V_{Sp\ max}$  depends on the maximum specific cooling capacity and the maximum temperature difference  $\Delta\theta_{max}$  in cooling mode (**diagram 1**). The supplied volume flow  $V_{Sp\ tats}$  must be less than this value. **Diagram 2** can be used to determine the minimum centre spacing between two air diffusers based on the maximum specific volume flow rate.

### Key for layout

- $V_A$  = volume flow rate per air outlet in l/s
- $V_{A\ max}$  = max. volume flow rate per air outlet when cooling in l/s
- $V_{A\ min}$  = min. volume flow rate per air outlet when cooling in l/s
- $V_{Sp\ max}$  = max. specific volume flow rate per  $m^2$  in  $l/(s.m^2)$
- $V_{Sp\ tats}$  = actual specific volume flow rate per  $m^2$  of floor area in  $l/(s.m^2)$
- $u$  = max. allowable indoor air velocity in m/s
- $q$  = max. specific cooling capacity in  $W/m^2$
- $\Delta\theta_{max}$  = max. temperature difference supply air to return air in K
- $t_{min}$  = minimum air outlet centre spacing in m
- $H$  = discharge height in m
- $L_{WA}$  = sound power level in dB(A) ref.  $10^{-12}$  W
- $\Delta p_t$  = total pressure drop in Pa

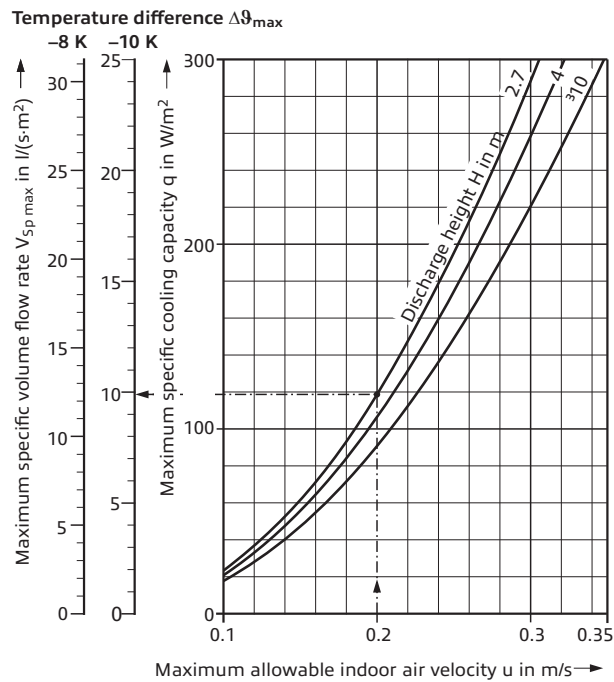

Diagram 1: Max. specific volume flow rate

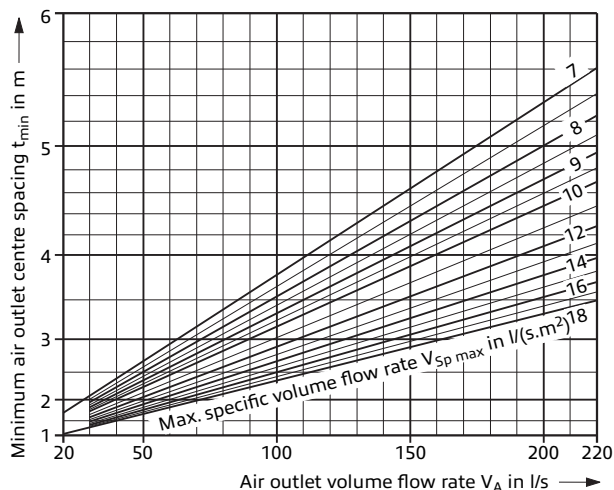

Diagram 2: Min. air diffuser center distance

Layout example		
Size		500
Application		Office building
1 Supply air volume flow rate $V$	l/s	666
2 Discharge height $H$	m	2.7
3 Floor area $A$	$m^2$	120
4 Maximum allowable sound power level $L_{WA}$ dB(A)		38
5 Temperature difference $\Delta\theta_{max}$	K	-10
6 Comfort criteria		
– Maximum indoor air velocity $u$	m/s	0,2
– Maximum specific volume flow rate $V_{Sp\ max}$	$l/(s.m^2)$	10
– Actual specific volume flow rate $V_{Sp\ tats}$	$l/(s.m^2)$	[from 1 : 3] 6
Criterion is met if $V_{Sp\ tats} < V_{Sp\ max}$		
From nomogram		
7 $V_{A\ max}$	l/s	111
8 $Z$ [ $\geq V : V_{A\ max}$ ]	units	6
9 $V_A$ [ $V : Z$ ]	l/s	111
10 $L_{WA}$	dB(A)	< 36
11 $\Delta p_t$	Pa	< 40
12 $t_{min}$ [Graph 2]	m	< 3.3

# Opticlean

## as supply air diffuser

### Pressure loss and sound power level

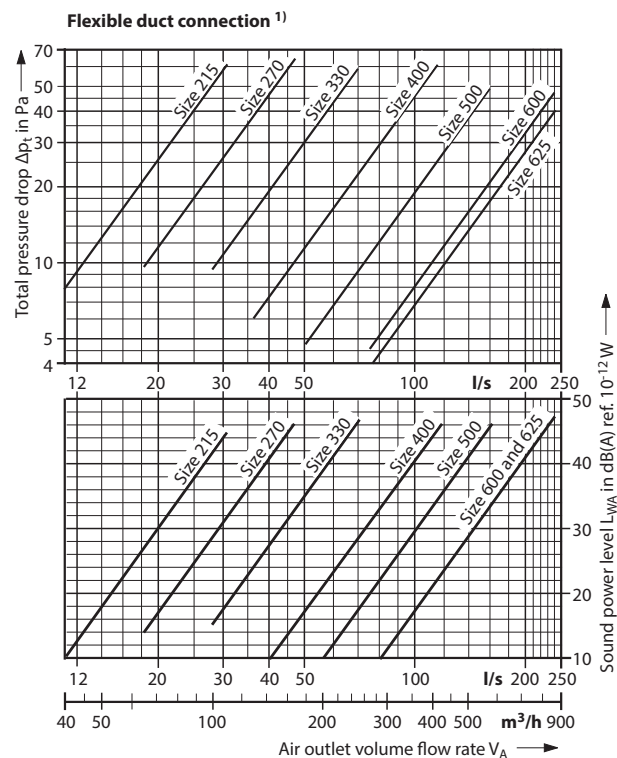

#### Notes

- Data of the sound power level related to the octave
- Sound power level are available on request
- The specifications for sound power level and pressure loss given here apply to the standard version and with a perforation Rd 2.8 - 5.5 (Rd2820).
- The design of the visible surface has an influence on the function and technical properties. If necessary, the suitability of other visible surfaces should be confirmed by measurements.
- Use flow stabilizer if the minimum air volume is not reached (page 3, table 1).

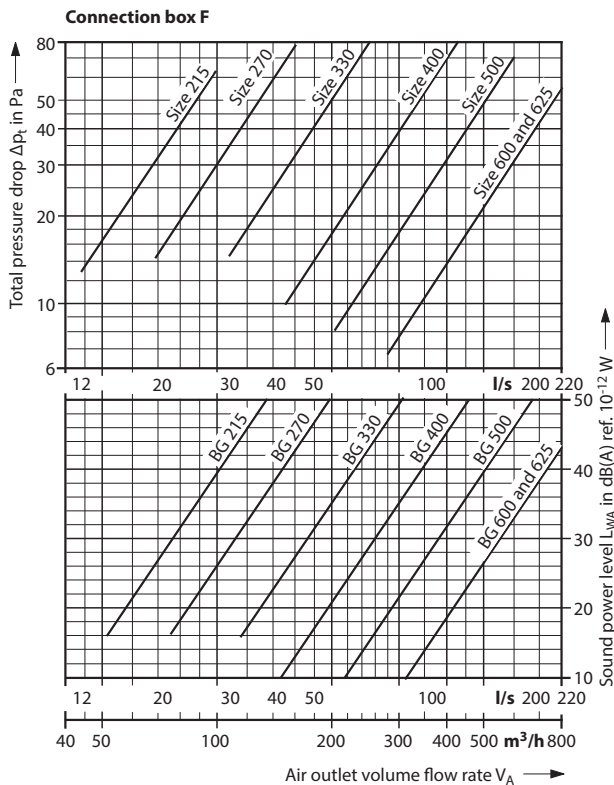
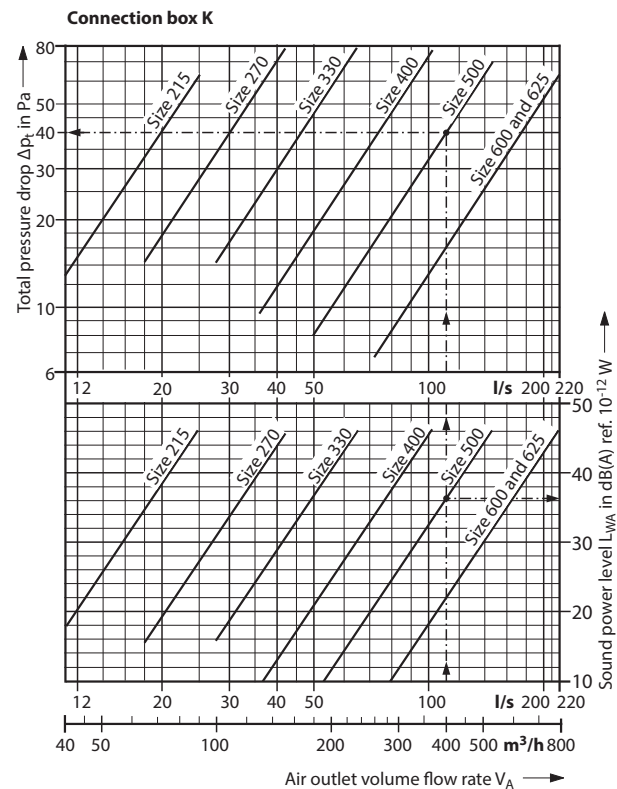



Pressure loss and sound power level

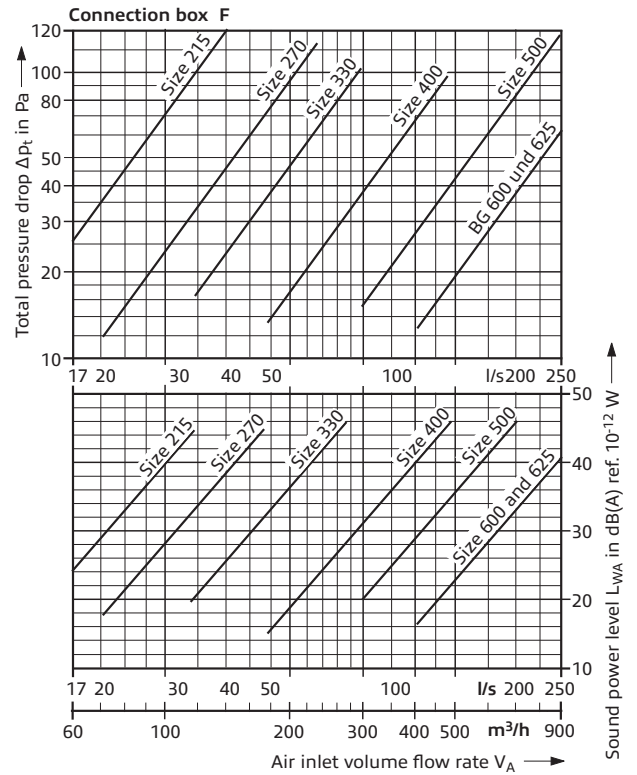
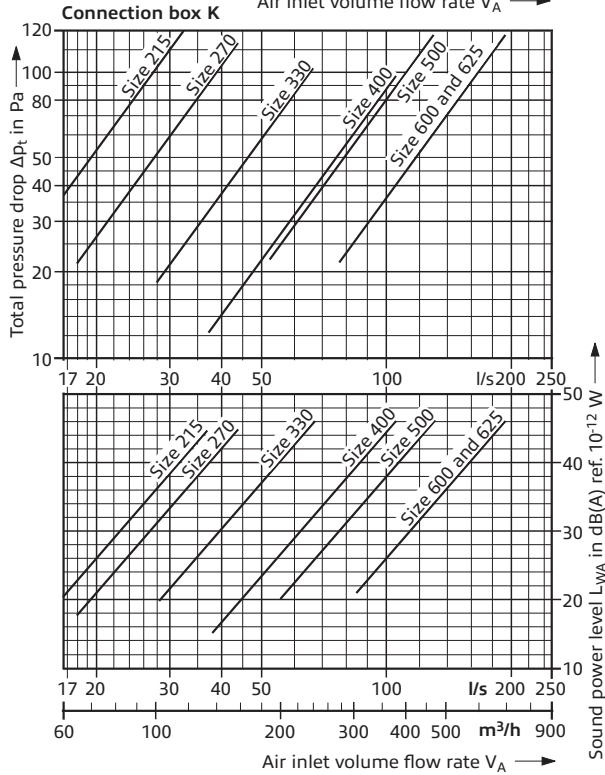
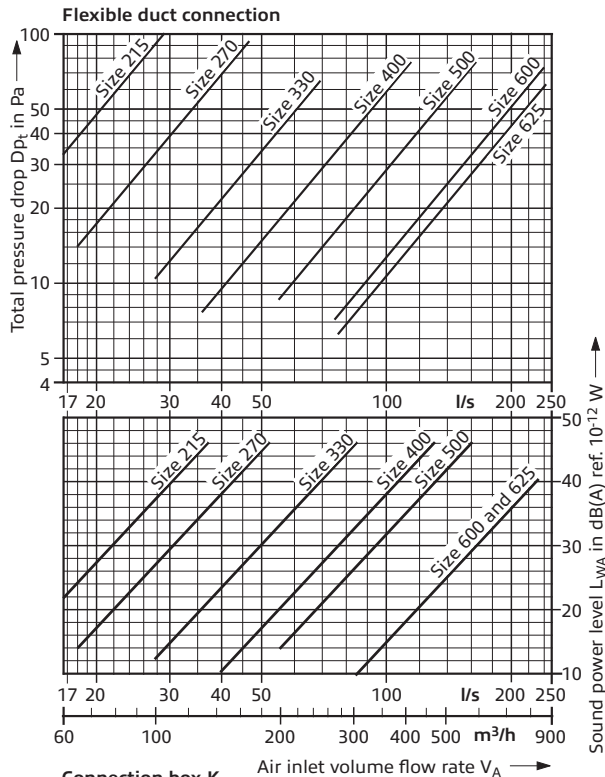

# Opticlean

## Features and tender text

### General

- Very uniform discharge, resulting in no or very low low ceiling contamination
- High thermal comfort due to diffuse room airflow
- Also useable as exhaust air inlet

### Technic

- Perforated square visible surface with round perforation  
Rd 2.8 - 5.5 (DIN 24041); other perforations on request
- 7 nominal sizes:  
215, 270, 330, 400, 500, 600 for grid ceiling and gypsum plasterboard  
+ 625 for grid ceilings
- Maximum temperature difference  
± 10 K up to 3 m room height  
± 5 K up to 4.5 m room height
- Volume flow rate range from 40 to 860 m<sup>3</sup>/h

### Installation

- Discrete integration into suspended ceilings
- For insertion in suspended ceiling systems, grid dimensions 600 and 625 mm and for gypsum plasterboard ceiling systems
- gypsum Plasterboard installation frame for gypsum plasterboard thicknesses of 12.5 mm  
also available for other gypsum Plasterboard thicknesses on request
- Special solutions for laying on perforated ceiling tile; technical clarification required
- Optional covers for wall and corner areas
- For pipe and tube connection, or with connection box
- On request with ultra-flat connection box for additionally reduced installation height

### Tender text

..... units

Opticlean – Supply air outlet with horizontal discharge for insertion into suspended ceiling systems with grid modules of 625 x 625 mm and 600 x 600 mm or for integration into 12.5 mm thick gypsum board ceilings, designed to generate a high-quality indoor air flow at low velocities and uniform indoor air temperatures;

unobtrusive integration into the ceiling;

extremely low amount of dirt accumulated on the ceiling thanks to very uniform air spread and the resultant air cushion.

consisting of:

- Faceplate with square visible surface, provided with a diagonally offset round perforation, hole diameter 2.8 mm, pitch 5.5 mm; deviating perforations on request and after technical clarification
- Optionally with mounting frame for installation in a 12.5 mm thick gypsum plasterboard ceiling; also available for other panel thicknesses on request
- Optionally with cover for 3-sided or 2-sided blowing out
- Air distribution element with top connection spigot for tube or pipe connection
- Optional connection box with lateral connection spigot as well as suspension brackets, optionally with volume flow restrictor, adjustable at the spigot

### Material

- Faceplate made of galvanized sheet metal powder coated to RAL ...
- Mounting frame made of galvanized sheet metal
- Air distribution element made of galvanized sheet metal
- Connection box made of galvanized sheet metal

Producer:Krantz GmbH

Make: Opticlean

Type: OC – Q\_ - \_\_\_ - - - - - \_\_\_\_

Example:

Grid ceiling: OC-Q1-215-0-F-S-9010-DKZI

Gypsum plasterboard: OC-QG-270-3-K-S-9010-DZ

Subject to technical alterations.

## Type code

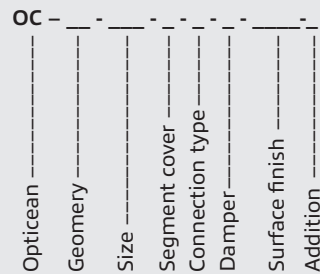

### Geometrie

- Q1 = square faceplate for square tile ceiling 600 x 600 mm
- Q2 = square faceplate for square tile ceiling 625 x 625 mm
- Q3 = Ceiling tile square custom size  
(technical clarification required)
- QG = square faceplate with mounting frame for 12.5 mm thick gypsum plasterboard ceiling  
(except for size 625)<sup>1)</sup>
- QY = Ceiling tile provided by the customer

### Size

- 215 = size 215
- 270 = size 270
- 330 = size 330
- 400 = size 400
- 500 = size 500
- 600 = size 600
- 625 = size 625

### Segment cover

- 0 = none (4-sided discharge)
- 1 = 3-sided discharge
- 2 = 2-sided symmetrical discharge
- 3 = 2-sided asymmetrical discharge

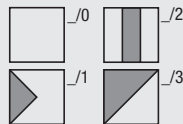

### Connection type

- O = no connection piece (only outlet element)
- K = Connection box; standard gypsum plasterboard
- F = Flat connection box; standard metal grid ceiling

### Damper

- O = no volume flow damper
- S = with volume flow damper adjustable at spigot

### Surface finish

- 9010 = face painted to RAL 9010, semi-matt
- ... = face painted to RAL ...

### Addition

- D = Lip gasket (only for connection type K and F)
- K = Clamping profiles (2 pieces per diffuser)
- Z = Flow stabilizer (only sizes 215 to 330)
- I = Internal insulation of the air distribution box
- A = Adhesive tape

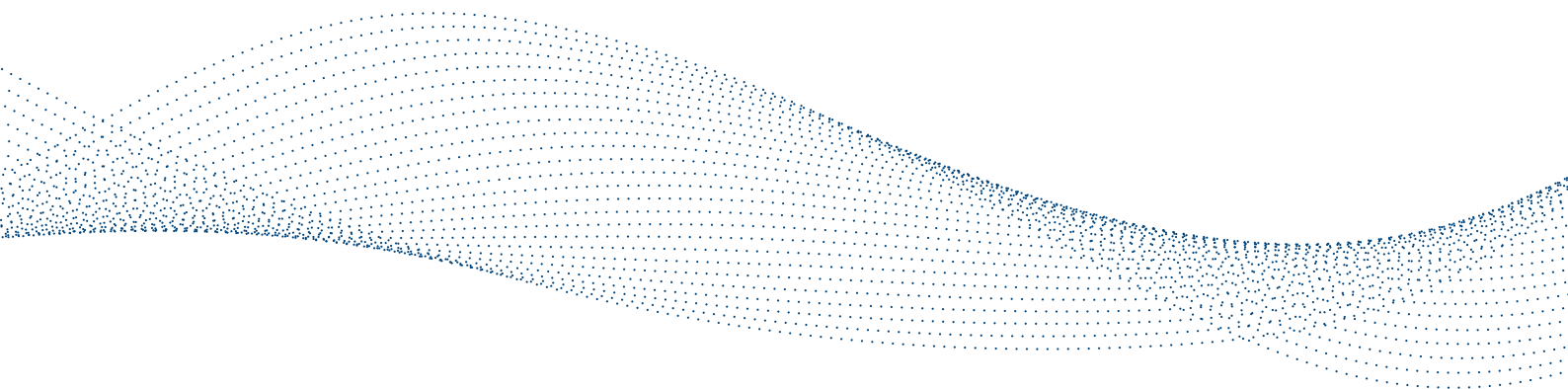

**Krantz GmbH**

Uersfeld 24, 52072 Aachen, Deutschland

Telefon: +49 241 441-1

Telefax: +49 241 441-555

info@krantz.de | www.krantz.de

The logo for Krantz GmbH, featuring the word "Krantz" in a stylized, blue, cursive script font.