

Head office

ELSTEAM S.r.l.
Piazzale Cesare Battisti 3,
32100 Belluno (BL)
ITALIA

Production

ELSTEAM S.r.l.
Via Enrico Fermi 496
21042 Caronno Pertusella (VA)
ITALIA
T +39 02 9659890
F +39 02 96457007
info@elsteam.it
www.elsteam.it

VEH OEM

Guide to the VEH OEM series for steam humidification

Included with the solution

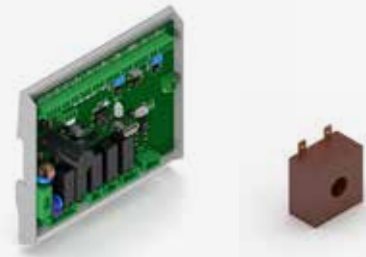

EHHKT e 0103349007
Electronic controller and current transformer

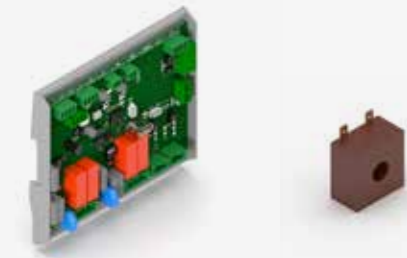

EHHKX expansion control required when two hydraulic steam production units are used

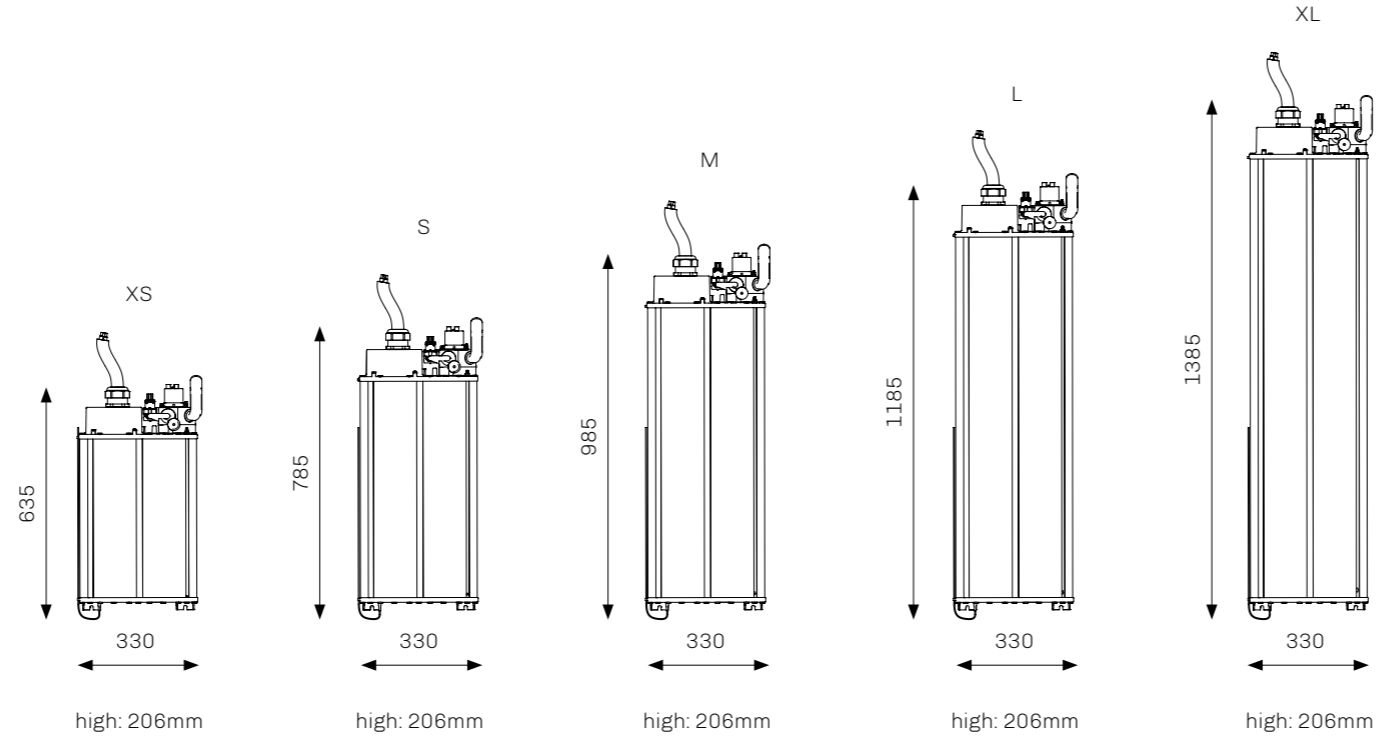

Increase your production capacity



- 160 kg/h with two 80 kg/h L units
- 120 kg/h with two 60kg/h XL units
- 200 kg/h with two 100 kg/h XL units

	XS		S			M		L			XL			
Production capacity [kg/h]	10	20	20	30	40	30	60	40	80	160	60	100	120	200
Electrodes [n]	4	7	4	7	7	4	7	4	7	14	4	7	8	14
Unit weight [kg]	15	18	18	20	24	20	26	24	31	62	26	33	52	66
Power consumption [kW]	7.5	15	15	22.5	30	30	45	30	60	120	45	75	90	150
Power supply [Vac, 50/60Hz]	400/460													
Phases [n]	3													
Current per phase [A]	11	22	22	32	43	32	65	43	87	174	65	108	130	216
Inlet water conductivity [μ S*cm]	75...1250													
Inlet water hardness [°f]	5...50													
Inlet water pressure [MPa/bar]	0,02...1/0,2...10													
Inlet water connection	M 3/4" GAS													
Water drain external diameter [mm]	40													
Operating conditions [°C, RH]	1...50, max. 80% non-condensing													
Storage conditions [°C, RH]	-10...70, max. 95% non-condensing													
Unit protection	IPX0													