

# KDY

Duct diffuser with nozzles to be mounted in ventilation ducts



## QUICK FACTS

- Easy to install
- Available for circular as well as rectangular ducts
- Guide vane control
- Flexible spread pattern
- Available in galvanized version
- Standard colour White RAL 9003
  - 5 alternative standard colours
  - Other colours upon request

AIR FLOW - SOUND PRESSURE ROOM ( $L_{p10A}$ *)						
KDY Size	25 dB(A)		30 dB(A)		35 dB(A)	
	l/s	m <sup>3</sup> /h	l/s	m <sup>3</sup> /h	l/s	m <sup>3</sup> /h
2-7	18	65	23	83	27	97
2-9	24	86	29	104	35	126
2-14	37	133	45	162	54	194
2-18	47	169	58	209	70	252
3-14	55	198	68	245	81	292
3-18	70	252	88	317	105	378
4-14	70	252	88	317	105	378
4-18	95	342	115	414	140	504

*Applies to diffuser, installed in the duct.*

*\*)  $L_{p10A}$  = Sound pressure incl. A-filter with 4 dB room attenuation and 10 m<sup>2</sup> room absorption area.*

# Technical description

## Design

The KDY is a rectangular supply air diffuser designed to be mounted directly in the side of either a rectangular or circular duct. The diffuser front is fitted with a number of aerodynamically formed nozzles. There is a fixed vane on the inside of the diffuser front which gives an even outward airflow through the whole unit. The diffuser is available with two, three or four rows of nozzles.

## Materials and surface treatment

The diffuser is manufactured in galvanized sheet steel and is painted.

- Standard colour:
  - White semi-gloss, lustre 40, RAL 9003/NCS S 0500-N
- Alternative standard colours:
  - Silver gloss, lustre 80, RAL 9006
  - Grey aluminium gloss, lustre 80, RAL 9007
  - White semi-gloss, lustre 40, RAL 9010
  - Black semi-gloss, lustre 35, RAL 9005
  - Grey semi-gloss, lustre 30, RAL 7037
- Non-painted finish and other colours available on request.

## Special

In addition to standard sizes, terminals with special dimensions or a number of nozzles can be supplied. It is also available in a galvanized version. Please contact your nearest sales representative for further information.

## Planning

The nozzles can be rotated 360° which means that an infinite number of spread patterns are available, both horizontally and vertically, without changing the pressure drop or the sound level.

**Note! Always specify the dimension of the duct where the terminal is to be mounted (see specification on the last page).**

## Installation

A hole is cut through the side of the duct in accordance with the specified hole making size. The KDY is then fastened to the duct with screws. See figure 1.

## Commissioning

For commissioning and measurement it is recommended that a measuring damper is installed before the first diffuser.

## Maintenance

The diffuser can be cleaned when necessary, using luke warm water and detergent.

## Environment

The Declaration of construction materials is available at [www.swegon.com](http://www.swegon.com).

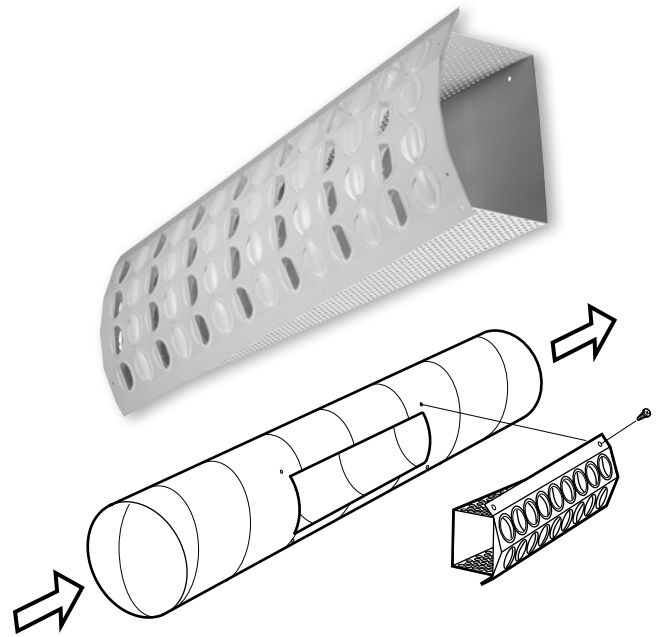

Figure 1. Installation.

**Table 1. Maximum number of diffusers in one duct branch.**

In order to obtain an even distribution to all of the diffusers in a duct branch, the number of diffusers fitted in one branch of a duct is limited as shown below for various duct dimensions.

Size of diffuser	Number of same diffuser type	Required duct dimension
2-7	4	160
	6	200
	8	250
2-9	4	200
	6	250
	8	315
2-14	4	250
	7	315
	10	400
2-18	3	250
	5	315
	10	400
3-14	4	315
	8	400
	10	500
3-18	3	315
	6	400
	10	500
4-14	5	400
	9	500
	10	630
4-18	4	400
	7	500
	10	630

# Sizing

- Sound pressure level dB(A) applies to rooms with 10 m<sup>2</sup> equivalent sound absorption area.
- Sound attenuation ( $\Delta L$ ) below is shown in the octave band. Orifice attenuation is included in the values.
- The throw  $l_{0,2}$  is applicable to isothermal conditions.
- The recommended maximum under temperature with a standard nozzle setting is 10°C.
- The maximum recommended air velocity before the first diffuser in one branch of a duct is 5 m/s
- For calculating the width of the air stream, air velocities in the occupied zone or sound levels in rooms with other dimensions, please refer to our web calculation softwares available for download at [www.swegon.com](http://www.swegon.com).

$L_w$  = Sound power level

$L_{p10A}$  = Sound pressure level dB (A)

$K_{ok}$  = Correction for producing the  $L_w$  value in the octave band

$L_w = L_{p10A} + K_{OK}$  gives the frequency divided octave band

## Sound data - KDY - Supply air

### Sound power level $L_w$ (dB)

Table  $K_{OK}$

Size KDYa	Mid-frequency (octave band) Hz							
	63	125	250	500	1000	2000	4000	8000
2-7	12	15	9	0	-8	-20	-29	-31
2-9	12	15	9	0	-8	-20	-29	-31
2-14	12	15	9	0	-8	-20	-29	-31
2-18	12	15	9	0	-8	-20	-29	-31
3-14	12	15	9	0	-8	-20	-29	-31
3-18	12	15	9	0	-8	-20	-29	-31
4-14	12	15	9	0	-8	-20	-29	-31
4-18	12	15	9	0	-8	-20	-29	-31
Tol. $\pm$	2	2	2	2	2	2	2	2

### Sound attenuation $\Delta L$ (dB)

Table  $\Delta L$

Size KDYa	Mid-frequency (octave band) Hz							
	63	125	250	500	1000	2000	4000	8000
2-7	15	10	5	1	1	0	0	0
2-9	15	9	5	2	1	1	0	0
2-14	13	8	3	1	0	0	0	0
2-18	12	7	3	1	0	0	0	0
3-14	12	7	3	1	0	0	0	0
3-18	11	6	2	1	0	0	0	0
4-14	11	6	2	1	0	0	0	0
4-18	9	5	2	0	0	0	0	0
Tol. $\pm$	2	2	2	2	2	2	2	2

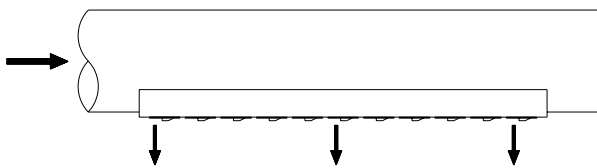

Figure 2. Installation alternative, not applicable to by-pass flow.

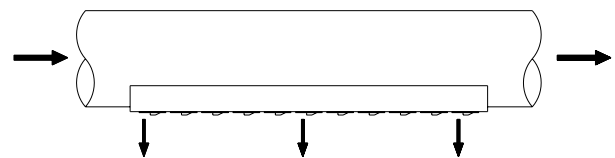

Figure 3. Installation alternative, by-pass flow.

**Engineering graphs - KDY - Supply air  
Air flow - Pressure drop - Sound level**

- The graphs are not to be used for commissioning
- The dB(A) values are for rooms with normal acoustic absorption of 4 dB.
- The dB(C) value is normally 6-9 dB higher than the dB(A) value. For more accurate calculations, see the calculation template in the chapter on Acoustics in the Technical Information section of this catalogue.
- With alternative nozzle setting (see Figure 5 illustrating nozzle settings),  $l_{0,2}$  is shortened by approx. 40%.

**KDYa C and R, 2 rows of nozzles**

By-pass flow.

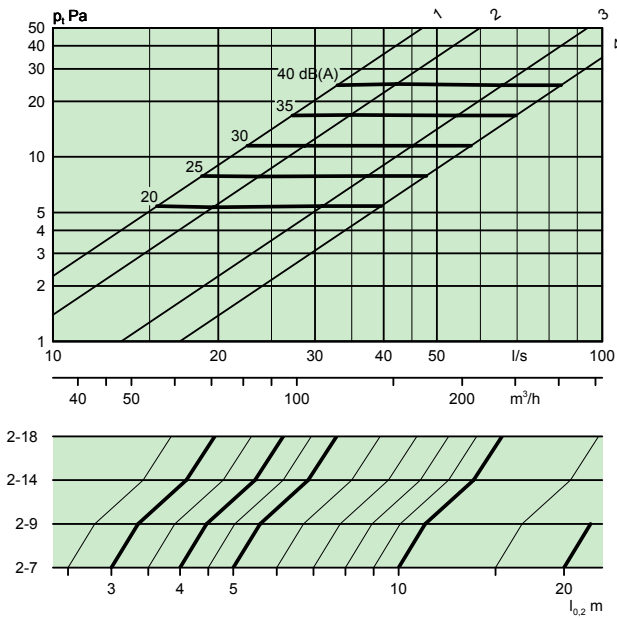

Size designation:

- 1 = size 2-7
- 2 = size 2-9
- 3 = size 2-14
- 4 = size 2-18

**KDYa C and R, 3 and 4 rows of nozzles**

By-pass flow.

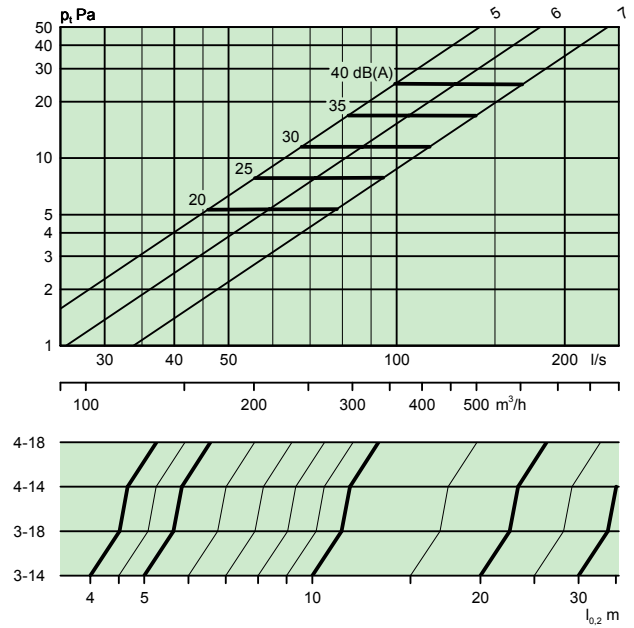

Size designation:

- 5 = size 3-14
- 6 = size 3-18 and 4-14
- 7 = size 4-18

**KDYa C and R, 2 rows of nozzles**

Not applicable to by-pass flow

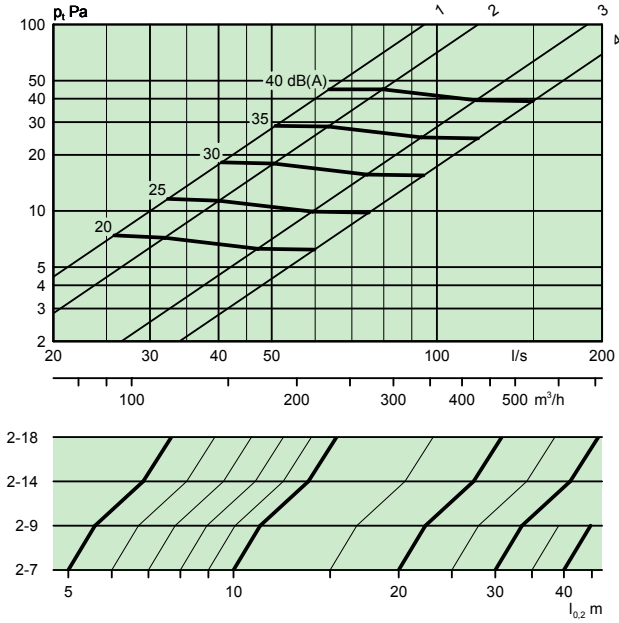

- Size designation:
- 1 = size 2-7
  - 2 = size 2-9
  - 3 = size 2-14
  - 4 = size 2-18

**KDYa C and R, 3 and 4 rows of nozzles**

Not applicable to by-pass flow

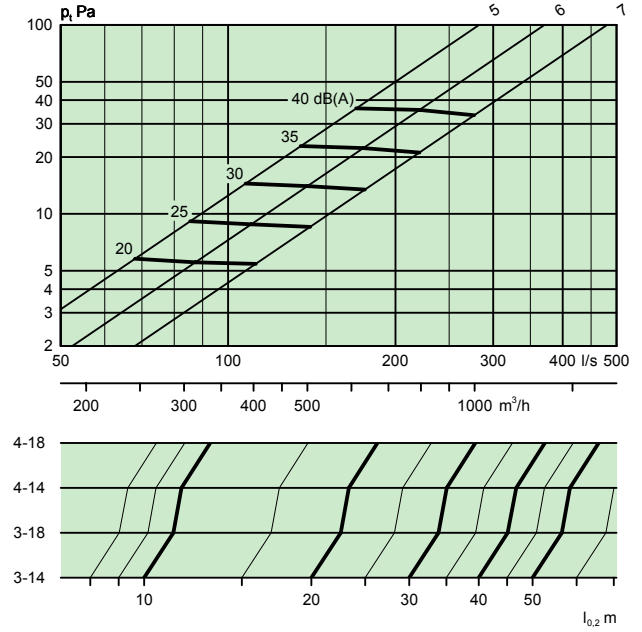

- Size designation:
- 5 = size 3-14
  - 6 = size 3-18 and 4-14
  - 7 = size 4-18

## Dimensions and weights

### KDYa-C

Size	A	C	I x J	Number of nozzles	Weight, kg
2-7	550	126	132 x 510	14	2.0
2-9	690	150	132 x 650	18	2.4
2-14	1040	170	132 x 1000	28	3.1
2-18	1320	205	132 x 1280	36	3.7
3-14	1040	175	197 x 1000	42	3.9
3-18	1320	210	197 x 1280	54	5.0
4-14	1040	195	262 x 1000	56	4.9
4-18	1320	230	262 x 1280	72	6.7

Hole-making size = I x J

Designed to fit duct dimensions according to the specification table on the last page.

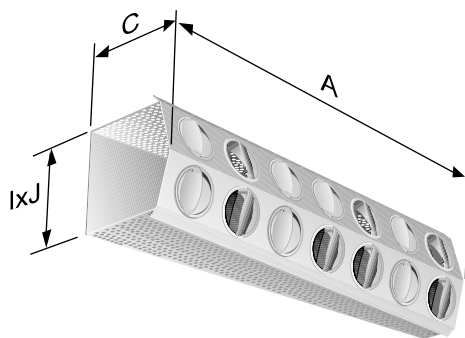

Figure 4. KDYa-C.

### KDYa-R

Size	A	B	C	I x J	Number of nozzles	Weight, kg
2-7	540	178	95	132 x 510	14	2.0
2-9	680	178	113	132 x 650	18	2.4
2-14	1030	178	160	132 x 1000	28	3.1
2-18	1310	178	190	132 x 1280	36	3.7
3-14	1030	243	160	197 x 1000	42	3.9
3-18	1310	243	190	197 x 1280	54	5.0
4-14	1030	307	160	262 x 1000	56	4.9
4-18	1310	307	190	262 x 1280	72	6.7

Hole-making size = I x J

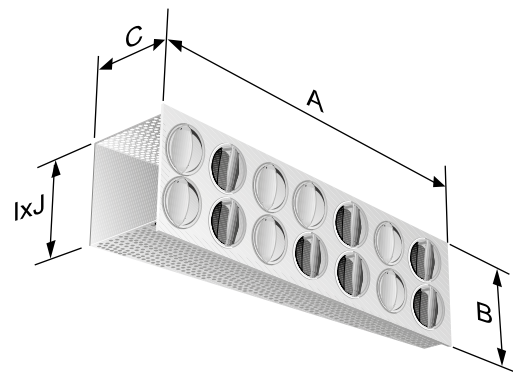
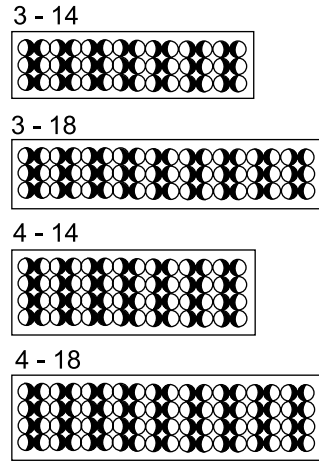
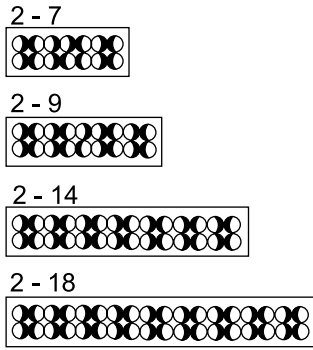

Figure 5. KDYa-R.

**Nozzle pattern KDY Standard**



**Nozzle pattern KDY alternative diffuse spread pattern**

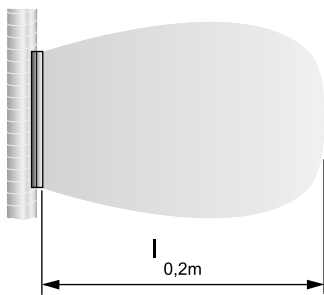
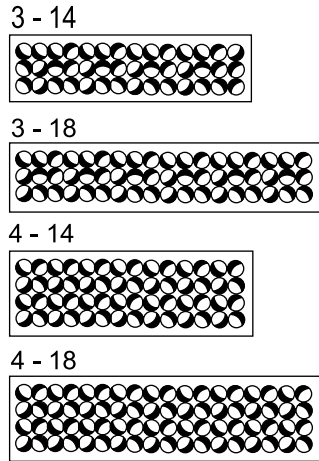
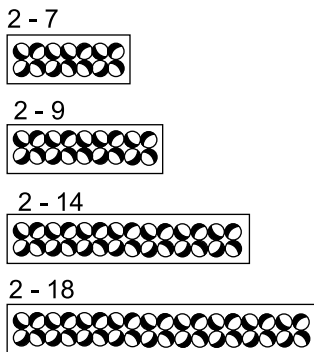

Figure 6. Standard nozzle pattern.

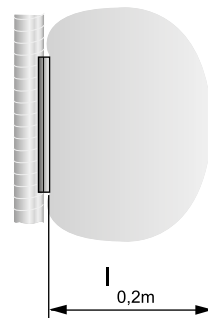

Figure 7. Alternative nozzle pattern, diffuse spread pattern.

# Order key

## Accessories

Nozzle diffuser for duct mounting	KDYa	-a	-b	-cc	-ddd
Suitable duct type:					
C Circular					
R Rectangular					
Number of nozzles height:					
Number of nozzles width:					
Dimensions in mm: (As below)					

# Specification example

Swegons rectangular nozzle diffuser of type KDYa for installation in circular or rectangular ducts having the following functions:

- 100% flexible spread pattern.
- Individually adjustable nozzles (55 mm) manufactured in recyclable ABS plastic.
- Fixed vane function.
- Powder-coated in white, RAL 9003/NCS S 0500-N..

Size: KDYa a - b - cc - ddd xx items

### Standard range Version C

Size	2-7- Ø160	3-14- Ø315
	2-7- Ø200	3-14- Ø400
	2-7- Ø250	3-14-Ø500
	2-9- Ø200	3-18- Ø315
	2-9- Ø250	3-18- Ø400
	2-9- Ø315	3-18-Ø500
	2-14- Ø250	4-14- Ø400
	2-14- Ø315	4-14- Ø500
	2-14- Ø400	4-14-Ø630
	2-18- Ø250	4-18- Ø400
	2-18- Ø315	4-18- Ø500
	2-18- Ø400	4-18-Ø630

### Standard range Version R

Size	2-7	200 mm
	2-9	200 mm
	2-14	200 mm
	2-18	200 mm
	3-14	250 mm
	3-18	250 mm
	4-14	350 mm
	4-18	350 mm