

IBIS

Duct diffuser with nozzles for supply air



QUICK FACTS

- 100% flexible distribution pattern
- Suspended installation
- Easy installation
- Modular length: 1500 mm
- Standard colour White RAL 9003
 - 5 alternative standard colours
 - Other colours upon request

IBIS Size	AIR FLOW - SOUND PRESSURE ROOM (Lp10A) *)					
	25 dB(A)		30 dB(A)		35 dB(A)	
	l/s	m ³ /h	l/s	m ³ /h	l/s	m ³ /h
160-1500-2	29	104	36	130	43	155
160-1500-4	40	144	48	173	56	202
160-3000-2	37	133	46	166	56	202
160-3000-4	47	169	57	205	69	248
200-1500-4	50	180	60	216	72	259
200-1500-6	62	223	76	274	86	310
200-3000-4	62	223	74	266	90	324
200-3000-6	77	277	90	324	110	396
250-3000-4	125	450	150	540	180	648
250-3000-6	145	522	170	612	205	738
250-4500-4	140	504	165	594	198	713
250-4500-6	158	569	180	648	215	774
315-3000-6	190	684	225	810	270	972
315-3000-8	220	792	260	936	310	1116
315-4500-6	215	774	255	918	305	1098
315-4500-8	230	828	270	972	325	1170
400-3000-8	285	1026	340	1224	410	1476
400-3000-10	320	1152	380	1368	455	1638
400-4500-8	330	1188	390	1404	470	1692
400-4500-10	355	1278	420	1512	500	1800
500-1500-12	300	1080	355	1278	420	1512
500-3000-12	450	1620	530	1908	625	2250
630-1500-16	400	1440	475	1710	570	2052
630-3000-16	650	2340	775	2790	900	3240

*) L_{p10A} = Sound pressure incl. A-filter with 4 dB room attenuation and 10 m² room absorption area.

Contents

Technical description	3
Materials and finish.....	3
Customizing.....	3
Project planning.....	3
Commissioning	3
Accessories	3
Maintenance.....	3
Environment	3
Technical data.....	5
IBIS – supply air – diffuser only.....	5
IBIS + IBIS Ca 1500	6
Throws	7
Airflow - Pressure drop - Sound level	8
Diagrams for IBIS – diffuser only.....	9
Diagrams for IBIS with control unit IBIS C	9
Dimensions and weights.....	13
Ordering key	15
Specification text.....	15

Technical description

Design

IBIS duct air diffuser with nozzles has a diameter that is compatible with standard duct sizes. IBIS is equipped with aerodynamically designed nozzles that have a high induction capacity. The 160 mm dia. and 200 mm dia. IBIS duct air diffusers are equipped with Swegon's small nozzles. The standard duct diffuser is available in a number of sizes as shown in Figure 8 (page 13) as well as in the Dimensions and weights table. There is an integrated strip on top that runs longitudinally for suspending the duct diffuser from the ceiling.

Materials and finish

The duct air diffuser with nozzles is made of galvanized sheet steel and is painted.

- Standard colour:
 - White semi-gloss, lustre 40, RAL 9003/NCS S 0500-N
- Alternative standard colours:
 - Silver gloss, lustre 80, RAL 9006
 - Grey aluminium gloss, lustre 80, RAL 9007
 - White semi-gloss, lustre 40, RAL 9010
 - Black semi-gloss, lustre 35, RAL 9005
 - Grey semi-gloss, lustre 30, RAL 7037
- Non-painted finish and other colours available on request.

The nozzles are made of recyclable environmentally friendly plastic (polypropylene-PP).

Customizing

In addition to the size specified, the duct diffusers are available in alternative sizes, number of nozzles, etc. For more info, get in touch with your nearest Swegon representative.

Project planning

The nozzles are rotatable through 360°. This makes it possible to achieve an infinite number of horizontal or vertical air diffusion combinations without altering the airflow, sound level or pressure drop.

The duct diffusers are well-suited for installation in the junction of a ceiling with a wall without reducing its flow capacity. The nozzles on the back side are then set for upward air discharge enabling the duct air diffuser to operate as a air diffuser with one-way air discharge. See Figures 1 and 2 for examples of principle air diffusion patterns.

Normal hanger length is 200 mm. The smallest permitted hanger length is 100 mm which generates slightly increased throw.

Commissioning

An IBIS C (see under accessories) or a flow measuring damper installed in the duct system upstream of the duct diffuser is recommended for commissioning and airflow measurements. The Methodic errors table and Figure 3 describes requirements on straight duct lengths for upstream obstructions.

Accessories

- IBIS D:** Duct section of the same design as IBIS but without nozzles.*)
- IBIS C:** Sound attenuating measurement and control unit.*)
- IBIS B:** 45° and 90° bend painted white.*)
- IBIS T:** T-piece painted white.*)

*) Available for sizes 160-400. For 500 and 630, standard accessories are recommended.

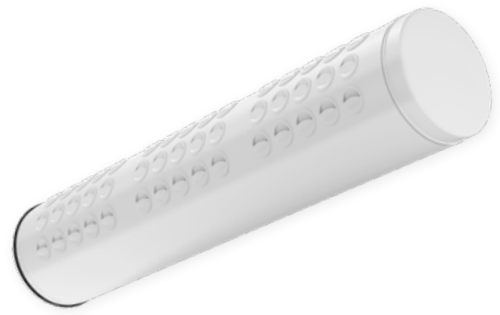

Maintenance

The air diffuser can be cleaned, if necessary, using lukewarm water with dishwashing detergent added or by vacuum cleaning using a brush nozzle.

Environment

The Declaration of Construction Materials is available from www.swegon.com.

Methodic Errors

Type of obstruction upstream of the IBIS C	Length of straight duct (L) upstream of the IBIS C	
	For $m_2=5\%$	For $m_2=10\%$
One 90° bend.	3 x Ød	2 x Ød
Two 90° bends in the same plane.	4 x Ød	2 x Ød
Two 90° bends in alignment at right angles to one another.	4 x Ød	2 x Ød
One 45° damper.	6 x Ød	3 x Ød
One T-piece.	4 x Ød	3 x Ød

m_2 = methodic error. Method for measurement of airflows in ventilation Installations.

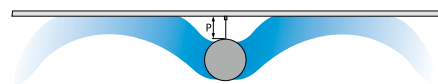

Figure 1. 2-way air discharge, P = 200 mm.



Figure 2. 1-way air discharge, P = 200 mm.

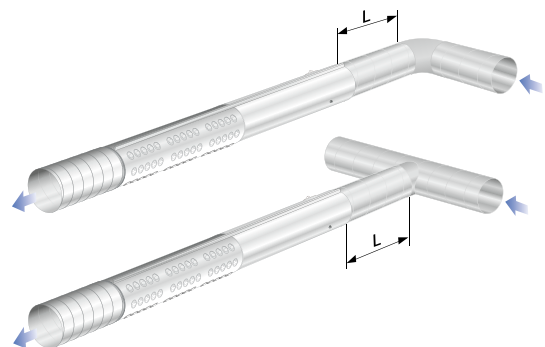

Figure 3. Project planning.

Installation

The duct diffuser is suspended by hangers from the ceiling. The air diffusers can be installed as in the following examples:

- The duct section (1) is placed on the floor. Insert the suspension bracket (2) approx. 100 mm in from the end on the longitudinal profiled rail (3).

NOTE! It is important that the rectangular washer on the suspension bracket rests against the rail, see the zoomed in image.

- Loosen the long nut slightly to create some space.
- Secure the bolts in the profiled bracket with long nuts (4). Screw a threaded rod (5) of appropriate length into each long nut.
- Secure the Z-profiled brackets (6) with bolts to the ceiling to serve as mounting brackets for the duct-shaped air diffusers with nozzles.
- Hang the duct air diffuser with nozzles (1) in the Z-profiled brackets (6) and join it together with the connecting supply air duct (7) using the standard duct joint (8) included in the supply.
- Adjust the duct air diffuser using the nuts (9) until the air diffuser is horizontal and at the correct height. The enclosed white plastic protection (15) is fitted onto the threaded rod.

Phase B

- Loosen the end cap (13) and move it to the outermost section if several sections are mounted. The duct diffuser with distribution nipple (10) must be mounted in the section (12).
- Insert the guide pin (11) in the free end of the installed section.
- Repeat phase A to install the next section (12). Mount a suspension bracket (2) with long nuts (4) at one end as the other is secured with the nipple to the section already installed. The distribution nipple (10) is secured with pan head screws in the sections. Repeat Phase B for last section.

Phase C

- Install the inactive IBIS D duct sections (14) in the same way as the duct air diffuser sections with nozzles. Note the use of supplied joints (8) and distribution joints (10) included in the supply.
- Position on delivery **I** and **II** Position after reassembly and installation. The end cap (13) is supplied mounted in the first section. Move the end cap to the last section if IBIS 3000 and IBIS 4500 are supplied., See Phase B in Figure 4.

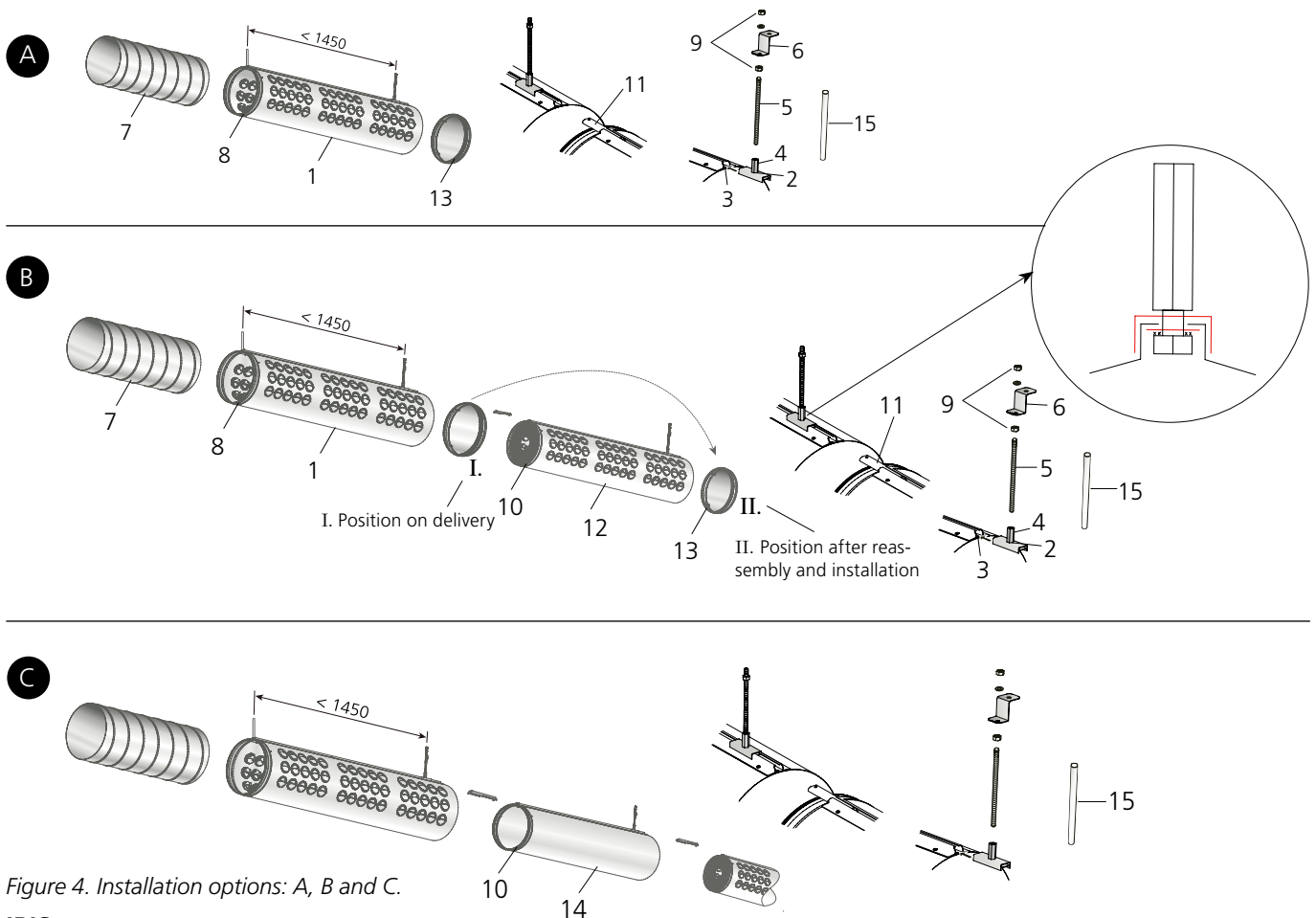

Figure 4. Installation options: A, B and C.

IBIS components

Size	Sections	Standard joint	Distribution joint	End cover	Set with installation accessories
IBIS -aaa-1500-c	1	1	-	1	1
IBIS -aaa-3000-c	2	1	1	1	2
IBIS -aaa-4500-c	3	1	2	1	3
IBIS D-aaa	1	1			1

Technical data

- Sound pressure level dB(A) applies to rooms with 10 m² equivalent sound absorption area.
- Sound attenuation (ΔL) below is shown in the octave band. Orifice attenuation is included in the values.
- Throw I_{0.2} is measured for isothermal air discharge and applies to installation 200 mm from the ceiling.
- A max. permissible temperature below room temperature of 8 °C is recommended for standard setting of the nozzles.
- The recommended highest permissible air velocity in the duct upstream of the air diffuser is 3-4 m/s.
- For calculating the air stream propagation, air velocities in the occupied zone, or sound levels in rooms with other dimensions, we refer to our calculation programs at www.swegon.com.

L_w = Sound power level

L_{p10A} = Sound pressure level dB (A)

K_{ok} = Correction for producing the L_w value in the octave band

L_w = L_{p10A} + K_{ok} gives the frequency divided octave band

Acoustic data

IBIS – supply air – diffuser only

Sound power level, L_w(dB)

Table K_{ok}

Size IBIS	Mid-frequency (Octave band) Hz							
	63	125	250	500	1000	2000	4000	8000
160-1500-2	-1	2	7	4	-2	-11	-21	-21
160-1500-4	-3	3	6	5	-5	-16	-25	-20
160-3000-2	-4	5	9	4	-5	-16	-23	-19
160-3000-4	-3	3	8	4	-6	-19	-26	-21
200-1500-4	1	4	8	4	-4	-14	-23	-20
200-1500-6	1	3	7	5	-5	-16	-22	-16
200-3000-4	1	5	10	3	-7	-19	-28	-20
200-3000-6	2	4	9	4	-8	-21	-28	-23
250-1500-4	2	8	9	3	-6	-15	-20	-20
250-1500-6	2	6	8	4	-5	-16	-19	-16
250-3000-4	4	8	10	2	-7	-16	-20	-18
250-3000-6	3	6	8	4	-6	-15	-18	-14
250-4500-4	1	8	10	2	-6	-15	-20	-19
250-4500-6	3	7	7	4	-5	-14	-18	-14
315-1500-6	1	7	10	2	-5	-17	-24	-25
315-1500-8	0	8	10	3	-6	-18	-21	-17
315-3000-6	2	9	10	2	-6	-19	-24	-23
315-3000-8	1	8	9	3	-6	-17	-19	-15
315-4500-6	2	9	10	2	-6	-18	-22	-21
315-4500-8	5	8	9	2	-6	-15	-16	-12
400-1500-8	4	9	9	2	-5	-15	-19	-17
400-1500-10	2	8	9	2	-5	-15	-20	-17
400-3000-8	5	11	10	2	-6	-17	-21	-19
400-3000-10	4	10	9	2	-6	-16	-18	-15
400-4500-8	4	11	10	2	-6	-17	-21	-19
400-4500-10	4	10	9	2	-6	-16	-19	-16
500-1500-12	3	8	8	3	-3	-14	-25	-25
500-3000-12	5	10	9	3	-5	-19	-26	-21
630-1500-16	2	9	7	4	-3	-15	-24	-21
630-3000-16	4	10	8	3	-5	-17	-20	-14
Tol. ±	2	2	2	2	2	2	2	2

Sound attenuation ΔL(dB)

Table ΔL

Size IBIS	Mid-frequency (Octave band) Hz							
	63	125	250	500	1000	2000	4000	8000
160-1500-2	21	15	9	5	2	1	0	0
160-1500-4	21	15	9	5	2	1	0	0
160-3000-2	21	15	9	5	2	1	0	0
160-3000-4	21	15	9	5	2	1	0	0
200-1500-4	16	10	5	2	1	0	0	0
200-1500-6	16	10	5	2	1	0	0	0
200-3000-4	16	10	5	2	1	0	0	0
200-3000-6	16	10	5	2	1	0	0	0
250-1500-4	10	6	5	2	1	0	0	0
250-1500-6	10	6	5	2	1	0	0	0
250-3000-4	10	5	4	1	1	0	0	0
250-3000-6	10	5	4	1	1	0	0	0
250-4500-4	10	5	4	1	0	0	0	0
250-4500-6	9	5	4	1	0	0	0	0
315-1500-6	9	6	4	1	1	0	0	0
315-1500-8	9	6	4	1	1	0	0	0
315-3000-6	9	6	4	1	1	0	0	0
315-3000-8	9	6	4	1	1	0	0	0
315-4500-6	9	5	4	2	0	0	0	0
315-4500-8	9	5	4	2	0	0	0	0
400-1500-8	9	5	3	2	1	0	0	0
400-1500-10	9	5	3	2	1	0	0	0
400-3000-8	9	5	3	1	0	0	0	0
400-3000-10	9	5	3	1	0	0	0	0
400-4500-8	9	5	3	1	0	0	0	0
400-4500-10	9	5	3	1	0	0	0	0
500-1500-12	8	4	3	1	1	1	1	1
500-3000-12	8	4	3	1	1	1	1	1
630-1500-16	6	3	2	1	1	1	0	0
630-3000-16	6	3	2	1	1	1	0	0
Tol. ±	2	2	2	2	2	2	2	2

IBIS + IBIS Ca 1500

Sound power level, L_w (dB)

Table K_{OK}

Size IBIS + IBIS C 1500	Mid-frequency (Octave band) Hz							
	63	125	250	500	1000	2000	4000	8000
160-1500-2	-1	6	7	3	-2	-10	-20	-22
160-1500-4	0	6	6	4	-3	-12	-23	-25
160-3000-2	3	8	8	3	-4	-13	-22	-23
160-3000-4	0	7	7	4	-4	-13	-22	-22
200-1500-4	0	7	8	4	-5	-14	-22	-25
200-1500-6	1	7	8	4	-6	-15	-23	-24
200-3000-4	0	8	9	3	-7	-16	-22	-24
200-3000-6	0	8	9	4	-7	-16	-22	-24
250-3000-4	5	9	8	3	-5	-11	-20	-22
250-3000-6	5	9	8	3	-5	-11	-20	-22
250-4500-4	3	8	7	3	-4	-7	-15	-21
250-4500-6	3	8	7	3	-4	-7	-15	-21
315-3000-6	4	9	9	2	-5	-14	-20	-23
315-3000-8	4	9	9	2	-5	-14	-20	-23
315-4500-6	4	9	9	2	-5	-14	-20	-23
315-4500-8	4	9	9	2	-5	-14	-20	-23
400-3000-8	4	10	9	2	-5	-14	-20	-23
400-3000-10	4	10	9	2	-5	-14	-20	-23
400-4500-8	4	9	9	2	-4	-12	-19	-23
400-4500-10	4	9	9	2	-4	-12	-19	-23

Not applicable to control unit with sizes 500 and 630

Sound attenuation ΔL (dB)

Table ΔL

Size IBIS + IBIS C 1500	Mid-frequency (Octave band) Hz							
	63	125	250	500	1000	2000	4000	8000
160-1500-2	30	20	14	10	8	11	17	14
160-1500-4	30	20	14	10	8	11	17	14
160-3000-2	30	20	14	10	8	11	17	14
160-3000-4	30	20	14	10	8	11	17	14
200-1500-4	20	15	11	10	10	17	17	14
200-1500-6	20	15	11	10	10	17	17	14
200-3000-4	20	15	11	10	10	17	17	14
200-3000-6	20	15	11	10	10	17	17	14
250-3000-4	16	13	9	11	14	22	17	15
250-3000-6	16	13	9	11	14	22	17	15
250-4500-4	16	13	9	11	14	22	17	15
250-4500-6	16	13	9	11	14	22	17	15
315-3000-6	15	10	7	8	11	15	10	11
315-3000-8	15	10	7	8	11	15	10	11
315-4500-6	15	10	7	8	11	15	10	11
315-4500-8	15	10	7	8	11	15	10	11
400-3000-8	11	7	5	6	8	11	9	9
400-3000-10	11	7	5	6	8	11	9	9
400-4500-8	11	7	5	6	8	11	9	9
400-4500-10	11	7	5	6	8	11	9	9

Not applicable to control unit with sizes 500 and 630

Throws

2-way air discharge, short

The throws for 2-way air discharge, short, are specified on the following pages in the sizing diagram.

Example:

IBD-315-3000-8 produces a flow of 260 l/s at 30 dB(A). A throw of 4.3 m is specified.

2-way air discharge, long

To calculate the throw for "2-way air discharge, long" multiply the throw in the relevant diagram by 1.75.

Example:

IBD-315-3000-8 produces a flow of 260 l/s at 30 dB(A). A throw of 4.3 m is specified. The throw for 2-way air discharge will then be: 1.75 x 4.3 m = 7.5 m

1-way air discharge

To calculate the throw for 1-way air discharge, multiply the throw in the relevant diagram by 2.0.

Example:

IBD-315-3000-8 produces a flow of 260 l/s at 30 dB(A). A throw of 4.3 m is specified. The throw for 1-way air discharge will then be: 2.0 x 4.3 m = 8.6 m

For the calculation of throws for air that is below or above room temperature, refer to our ProAir air diffuser selection program which is available at www.swegon.com.

Correction factor for hanger lengths

Throw for different hanger lengths according to table below. Throw illustrated in catalog diagrams refers to hanger length A = 200 mm.

$$I_{0,2} = K_p \times I_{0,2 \text{ standard}}$$

Hanger length A	K _p
300 mm	0,85
200 mm	1,0
100 mm	1,15
0 mm ^{*)}	1,2

^{*)} Direct installation against ceilings can only be done for 2-way air discharge, according to figure 6.

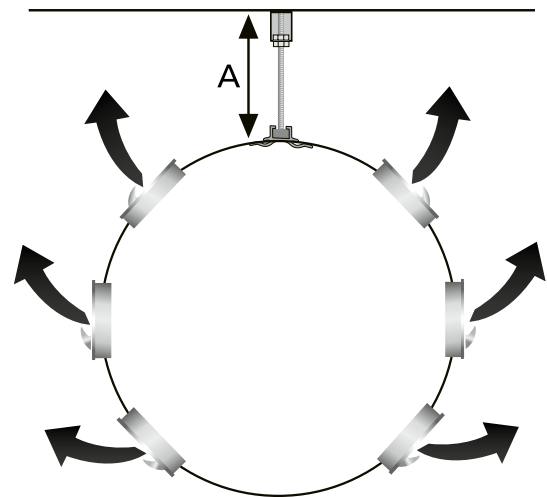

Figure 5. 2-way with short throw length. All the nozzles are directed upward toward the mounting strip.

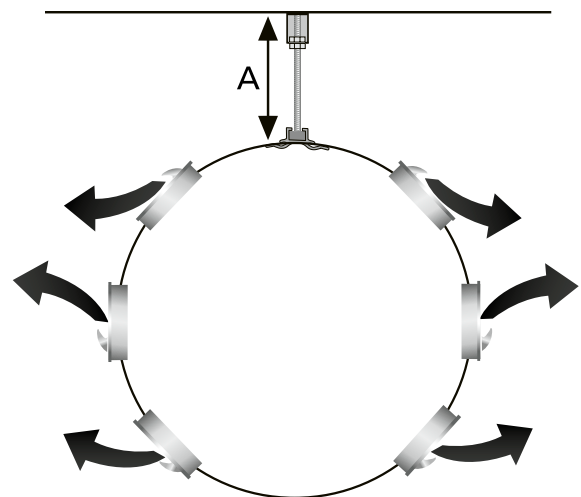

Figure 6. 2-way with long throw length. The uppermost row of nozzles on both sides of the mounting strip should face downward.

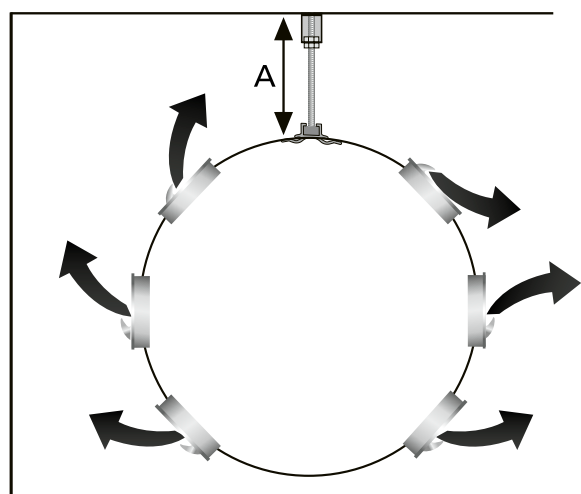

Figure 7. 1-way air discharge toward a wall. The uppermost row of nozzles on the air diffuser half facing the room should discharge air downward; the other nozzles should discharge air upward.

Sizing diagram

Airflow - Pressure drop - Sound level

- The diagram should not be used for commissioning.
- The dB(A) values are for rooms with normal acoustic absorption (4 dB room attenuation).
- The dB(C) value is normally 6-9 dB higher than the dB(A) value.

IBIS 160-630 all 1500

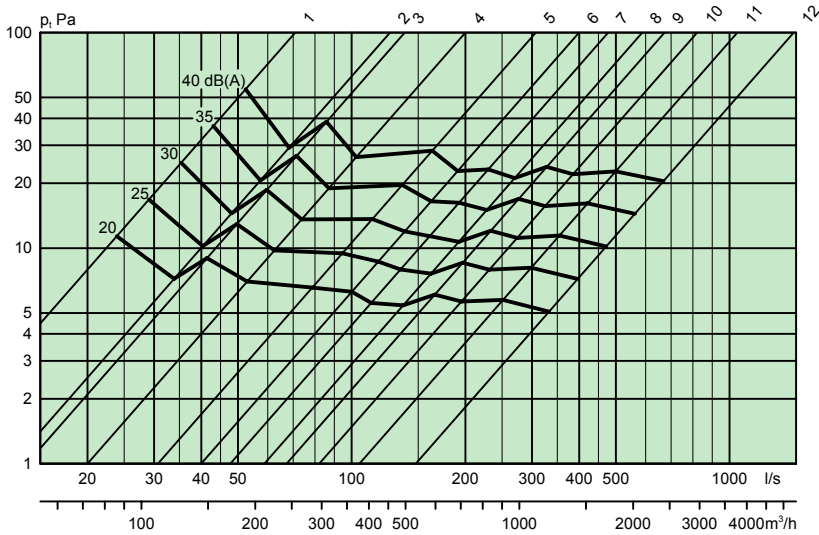

1. IBIS 160-1500-2
2. IBIS 160-1500-4
3. IBIS 200-1500-4
4. IBIS 200-1500-6
5. IBIS 250-1500-4
6. IBIS 250-1500-6
7. IBIS 315-1500-6
8. IBIS 315-1500-8
9. IBIS 400-1500-8
10. IBIS 400-1500-10
11. IBIS 500-1500-12
12. IBIS 630-1500-16

IBIS 160-400 all 3000

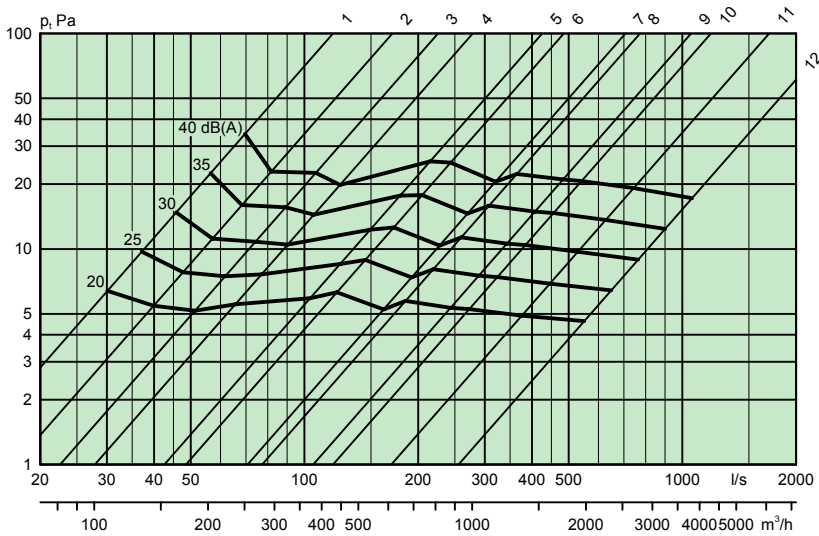

1. IBIS 160-3000-2
2. IBIS 160-3000-4
3. IBIS 200-3000-4
4. IBIS 200-3000-6
5. IBIS 250-3000-4
6. IBIS 250-3000-6
7. IBIS 315-3000-6
8. IBIS 315-3000-8
9. IBIS 400-3000-8
10. IBIS 400-3000-10
11. IBIS 500-3000-12
12. IBIS 630-3000-16

IBIS 250-400 4500

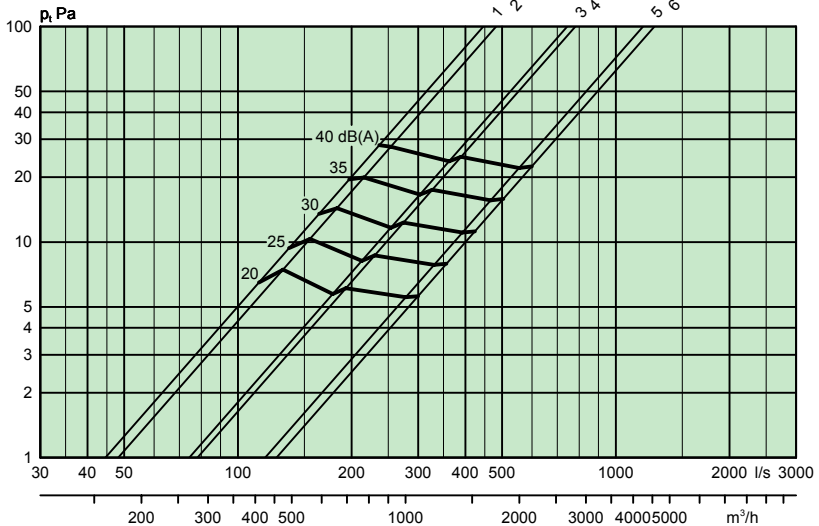

1. IBIS 250-4500-4
2. IBIS 250-4500-6
3. IBIS 315-4500-6
4. IBIS 315-4500-8
5. IBIS 400-4500-8
6. IBIS 400-4500-10

Diagrams for IBIS – diffuser only

IBIS 500

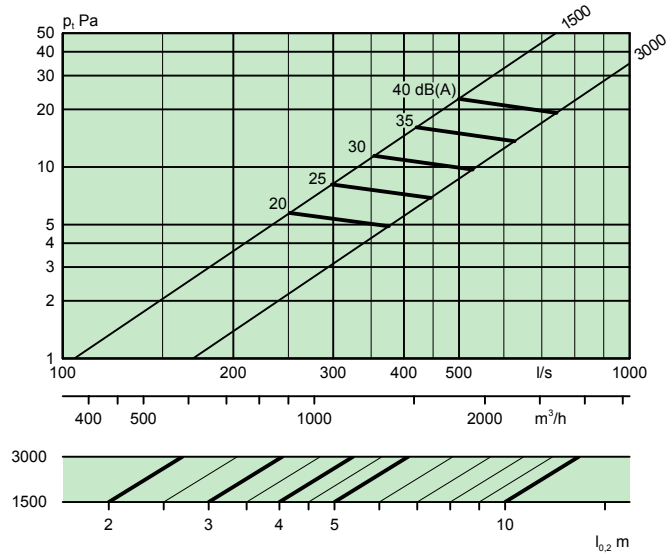

IBIS 630

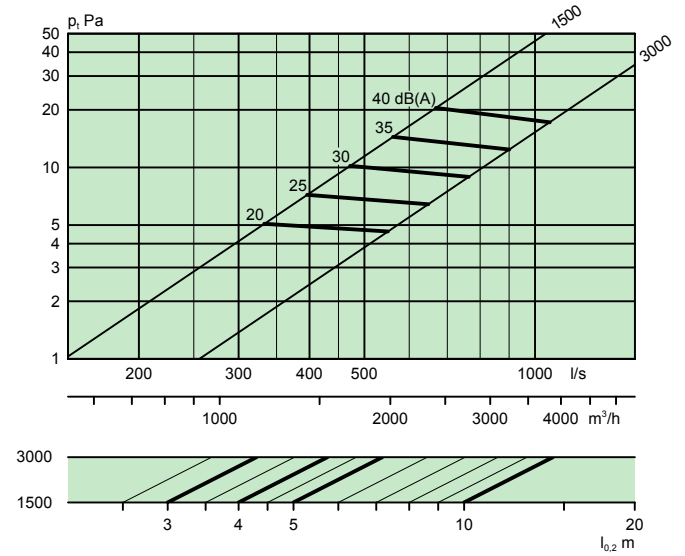

Diagrams for IBIS with control unit IBIS C

IBIS 160-1500-2 + IBIS C 1500

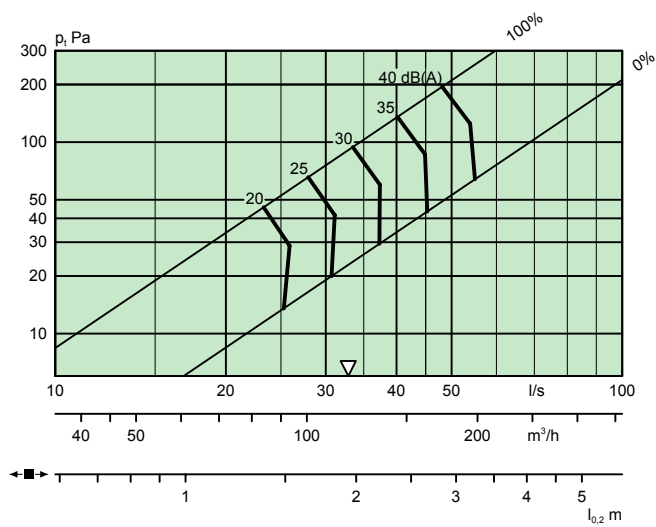

IBIS 160-1500-4 + IBIS C 1500

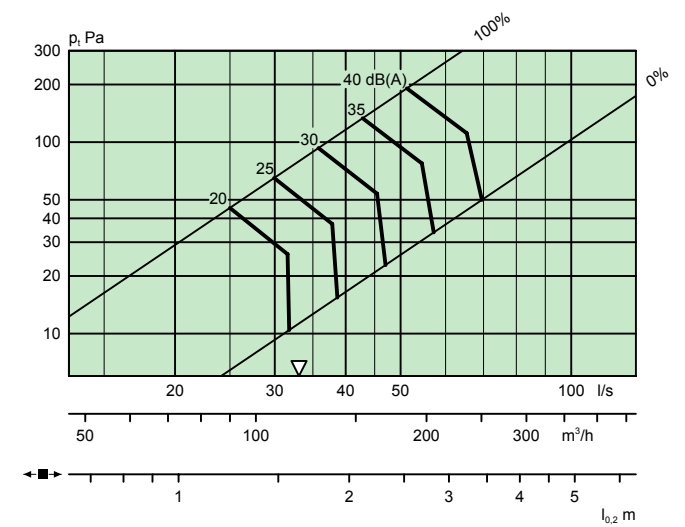

IBIS 160-3000-2 + IBIS C 1500

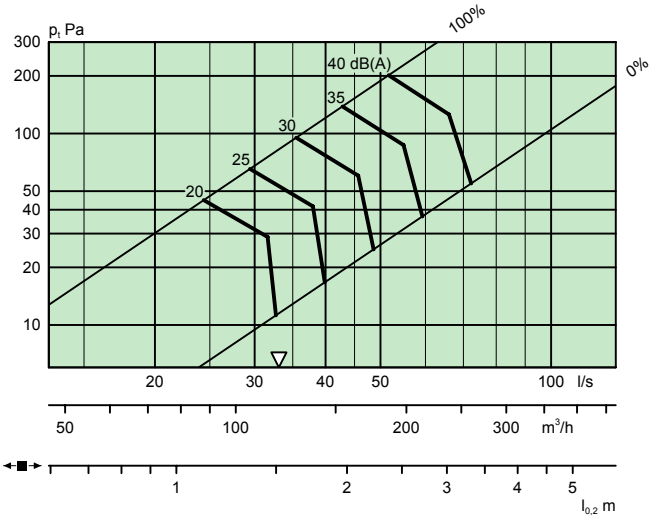

IBIS 160-3000-4 + IBIS C 1500

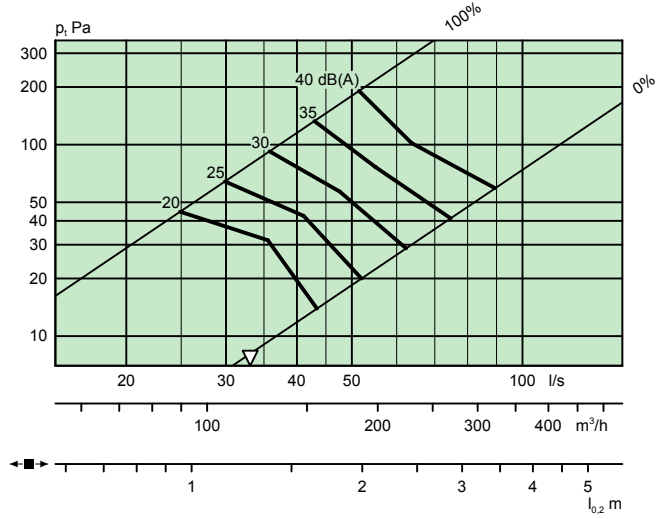

IBIS 200-1500-4 + IBIS C 1500

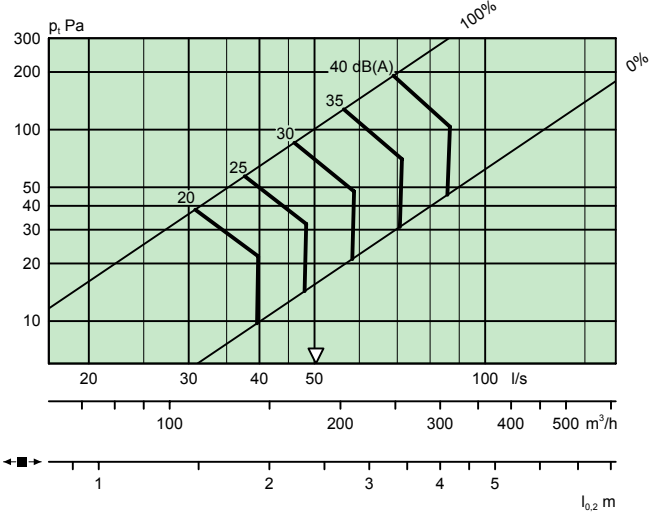

IBIS 200-1500-6 + IBIS C 1500

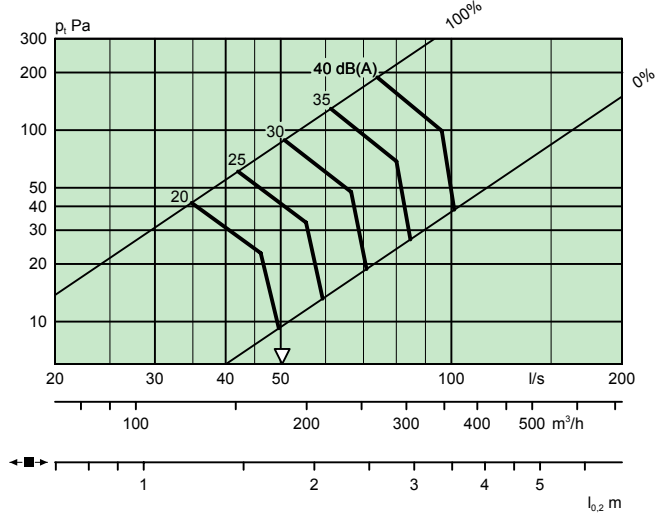

IBIS 200-3000-4 + IBIS C 1500

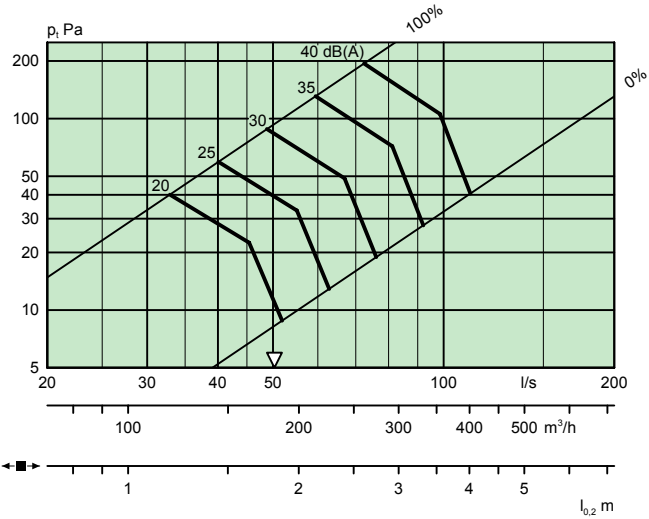

IBIS 200-3000-6 + IBIS C 1500

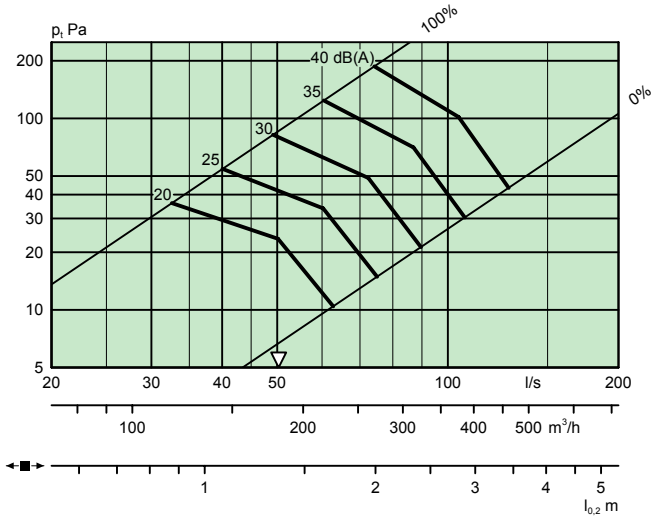

IBIS 250-3000-4 + IBIS C 1500

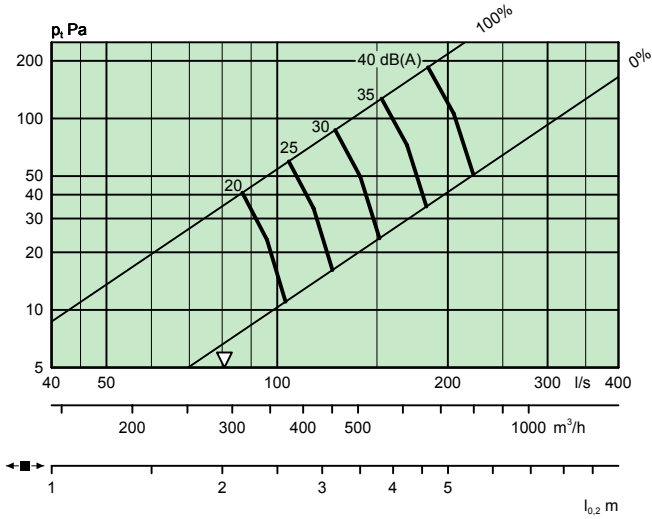

IBIS 250-3000-6 + IBIS C 1500

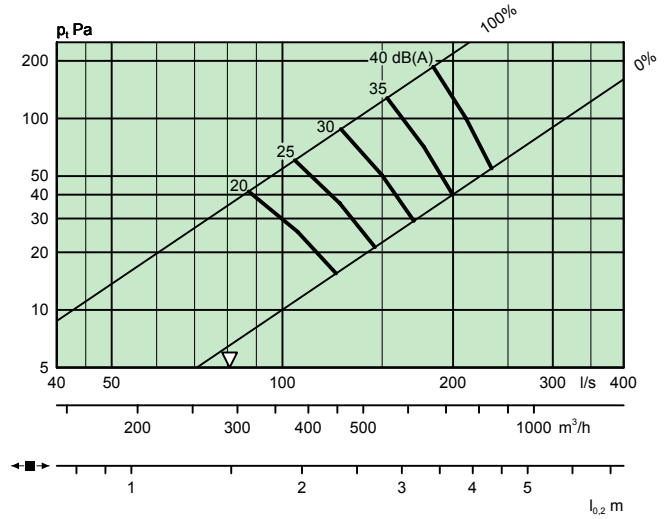

IBIS 250-4500-4 + IBIS C 1500

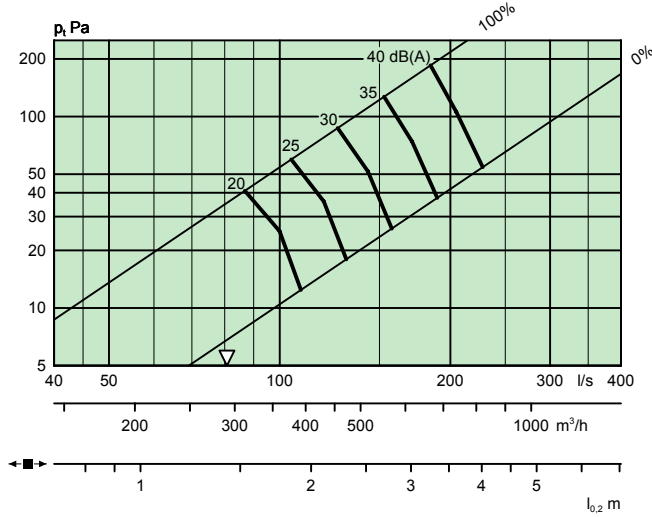

IBIS 250-4500-6 + IBIS C 1500

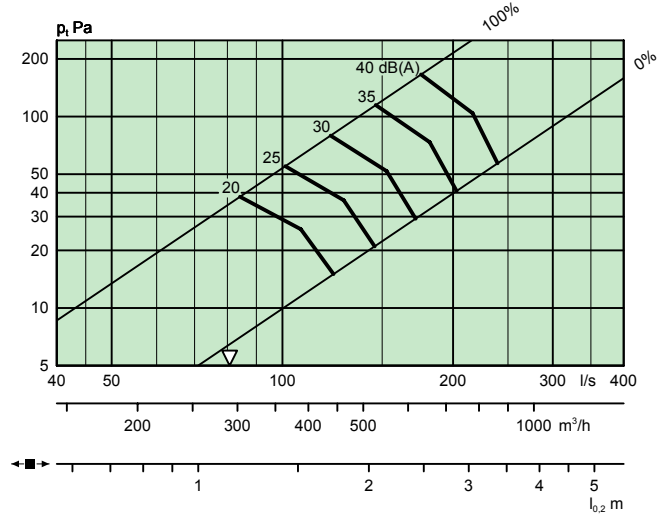

IBIS 315-3000-6 + IBIS C 1500

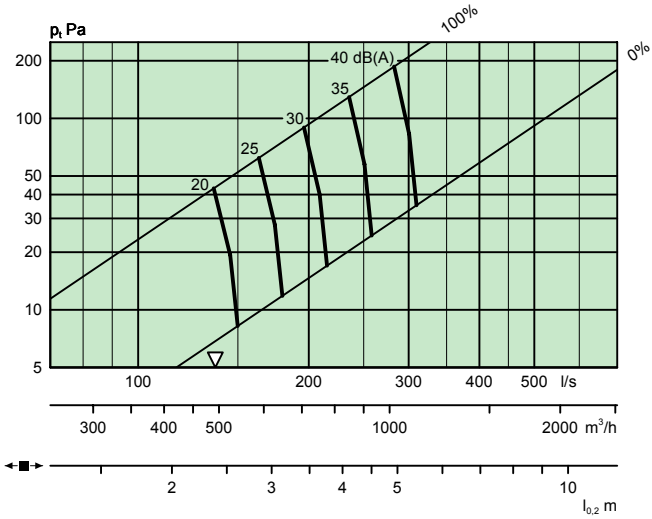

IBIS 315-3000-8 + IBIS C 1500

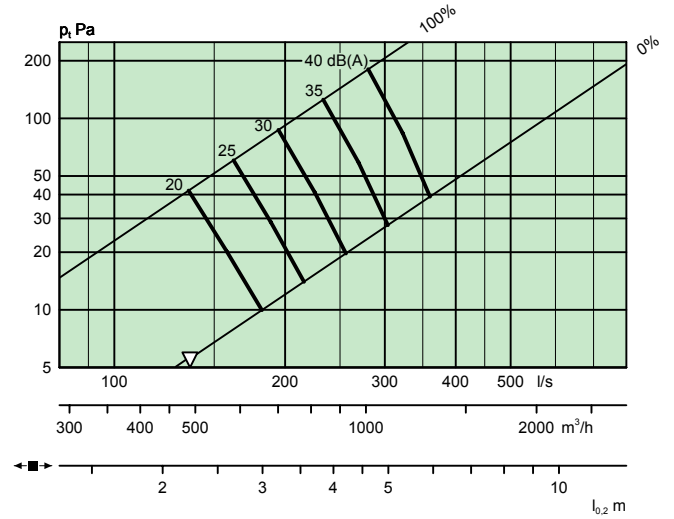

IBIS 315-4500-6 + IBIS C 1500

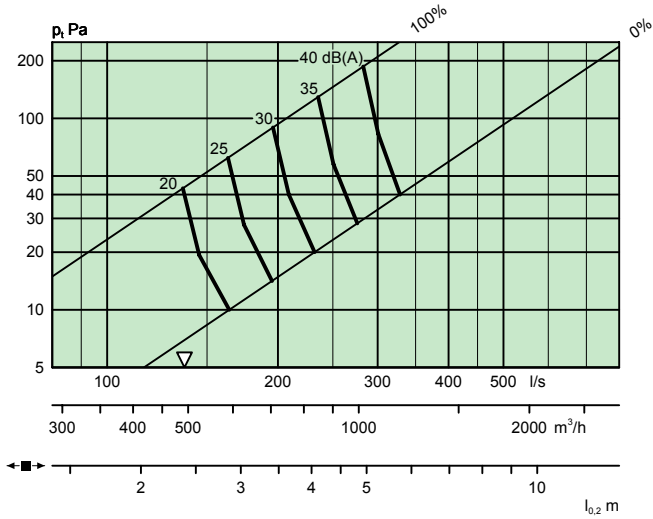

IBIS 315-4500-8 + IBIS C 1500

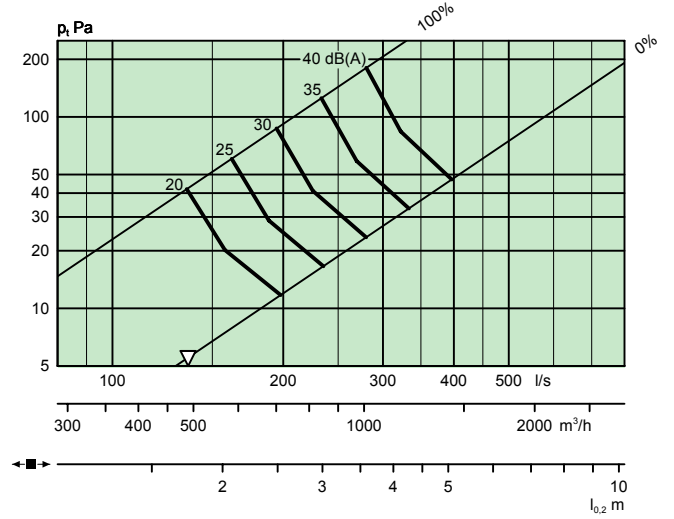

IBIS 400-3000-8 + IBIS C 1500

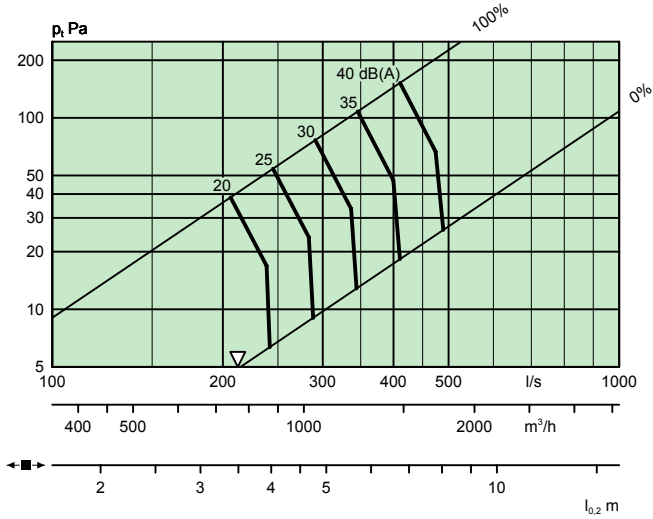

IBIS 400-3000-10 + IBIS C 1500

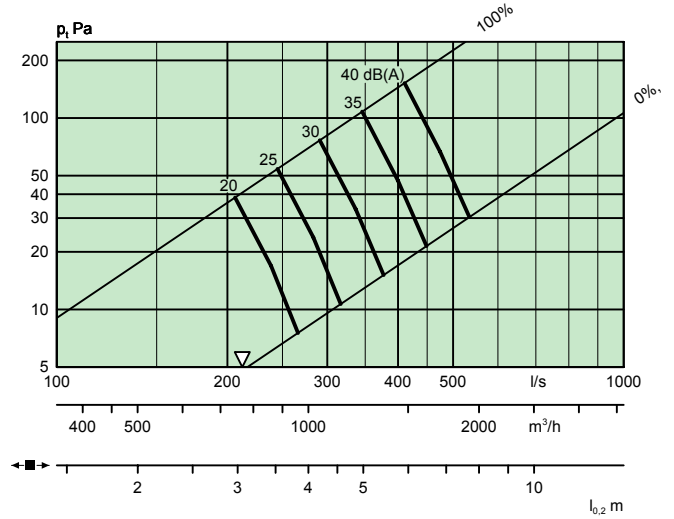

IBIS 400-4500-8 + IBIS C 1500

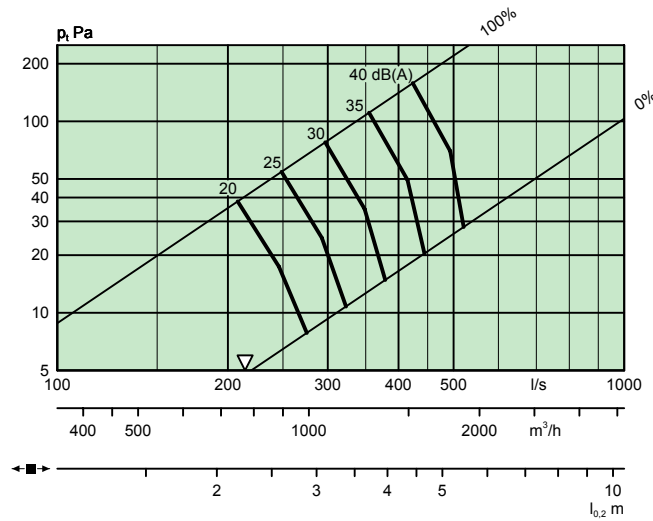

IBIS 400-4500-10 + IBIS C 1500

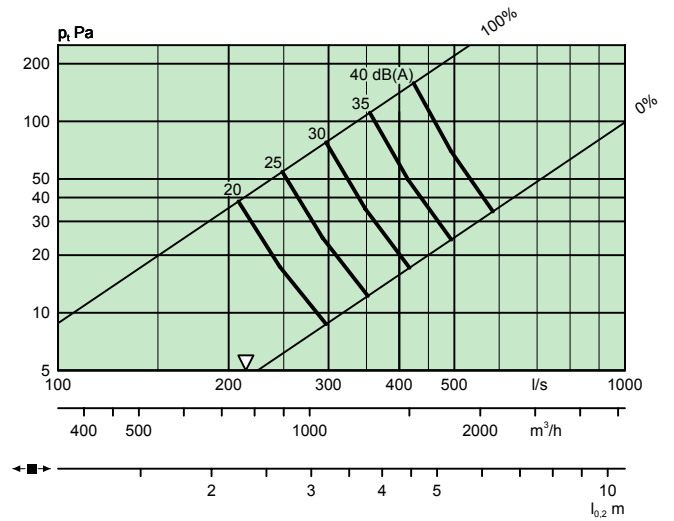

Dimensions and weight

Size	ØD (mm)	L1* = Install size (mm)	L2* = Overall size (mm)	m*)	n*)	Weight (kg)
160-1500-2	159	1455	1495	1	30	6,3
160-1500-4	159	1455	1495	1	60	6,3
160-3000-2	159	2910	2950	2	60	12,4
160-3000-4	159	2910	2950	2	90	12,4
200-1500-4	199	1455	1495	1	60	7,6
200-1500-6	199	1455	1495	1	90	7,5
200-3000-4	199	2910	2950	2	120	14,8
200-3000-6	199	2910	2950	2	180	14,6
250-1500-4	249	1455	1495	1	60	8,0
250-1500-6	249	1455	1495	1	90	7,9
250-3000-4	249	2910	2950	2	120	15,5
250-3000-6	249	2910	2950	2	180	15,4
250-4500-4	249	4365	4405	3	180	23,0
250-4500-6	249	4365	4405	3	270	22,8
315-1500-6	314	1455	1495	1	90	10,0
315-1500-8	314	1455	1495	1	120	9,9
315-3000-6	314	2910	2950	2	180	19,3
315-3000-8	314	2910	2950	2	240	19,2
315-4500-6	314	4365	4405	3	270	28,5
315-4500-8	314	4365	4405	3	360	28,4
400-1500-8	399	1455	1495	1	120	12,8
400-1500-10	399	1455	1495	1	150	12,7
400-3000-8	399	2910	2950	2	240	24,4
400-3000-10	399	2910	2950	2	300	24,3
400-4500-8	399	4365	4405	3	360	36,1
400-4500-10	399	4365	4405	3	450	35,9
500-1500-12	499	1455	1495	1	180	16,1
500-3000-12	499	2910	2950	2	360	30,6
630-1500-16	629	1455	1495	1	240	20,0
630-3000-16	629	2910	2950	2	480	37,6

*Dimensions without end cap.
 Weight including end cap.
 m*) = Number of duct modules.
 n*) = Number of nozzles.

Sound attenuating measurement and control unit IBIS C	
Size	Weight (kg)
160-1500	7,0
200-1500	8,0
250-1500	8,5
315-1500	10,5
400-1500	13,0

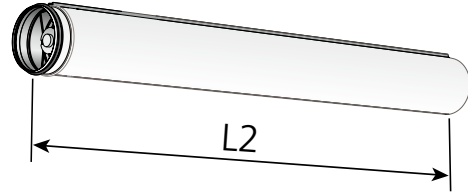
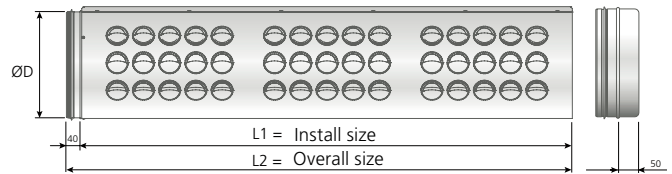

Figure 8. IBIS and IBIS D (The dimension refers to one section). End cap, dimension show the increase when assembled.

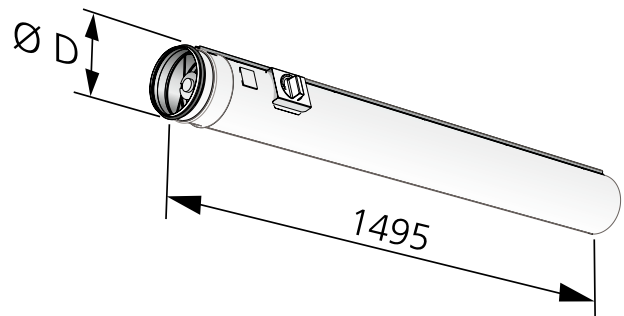

Figure 9. IBIS C, Available for sizes 160-400, not for sizes 500 and 630.

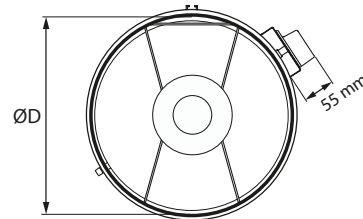

Figure 10. IBIS C, Available for sizes 160-400, not for sizes 500 and 630.

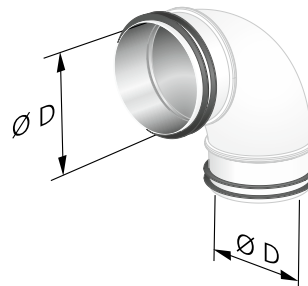

Figure 11. IBIS B, Available for sizes 160-400, not for sizes 500 and 630.

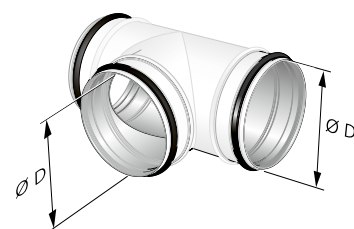

Figure 12. IBIS T, Available for sizes 160-400, not for sizes 500 and 630.

Nozzle settings

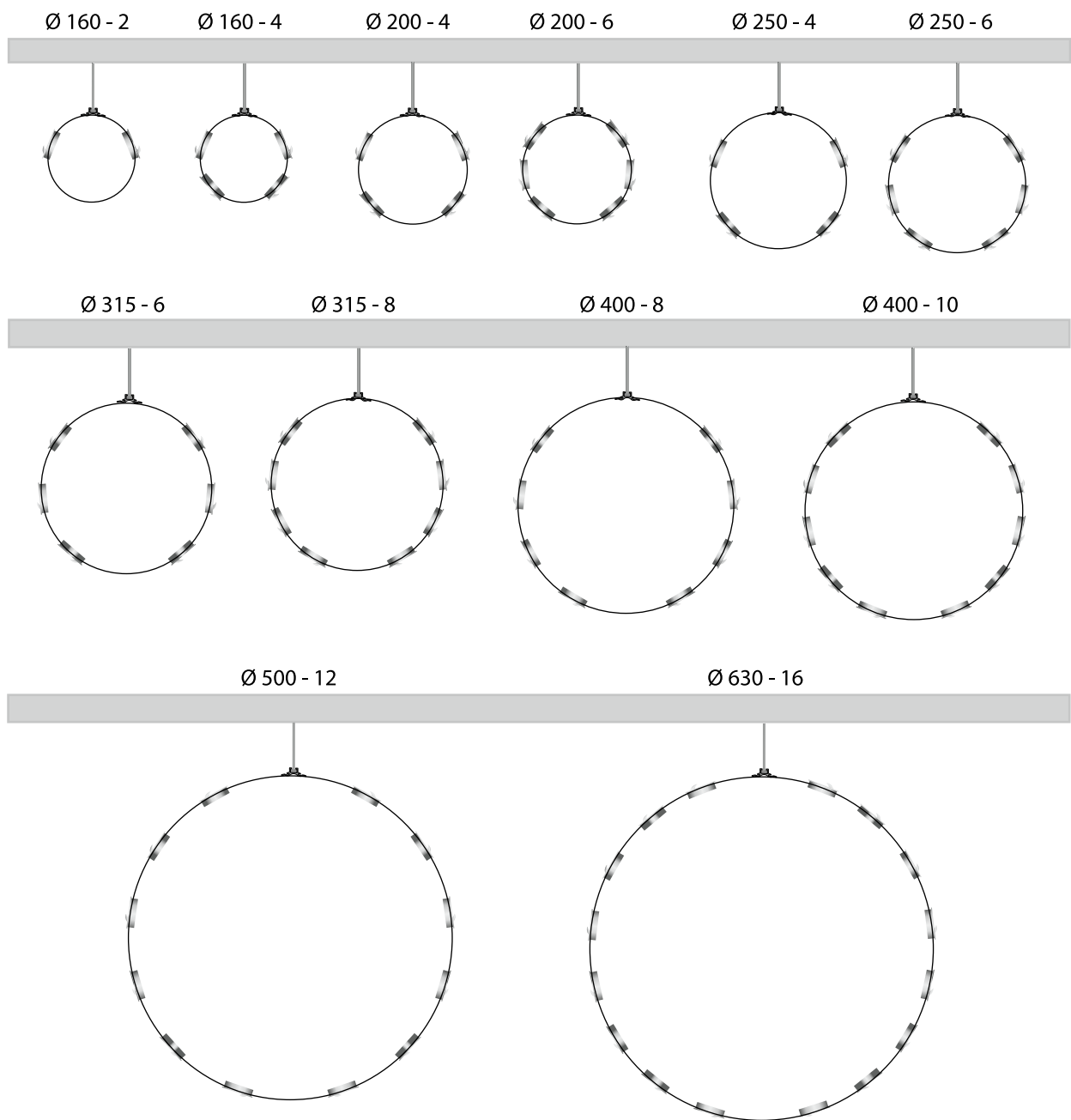

Figure 13. Arrangement of the nozzles.

Ordering key

Product

IBIS Duct air diffuser with nozzles
For suspended installation from the ceiling

Version

Size: 160, 200, 250, 315, 400, 500 and 630

Nom. length: 1500, 3000, 4500*)

Number of nozzle rows: 2, 4, 6, 8, 10, 12 and 16.

Accessories

Duct section. Nom. length of 1500 mm

Version

Size: 160, 200, 250, 315 and 400

Sound attenuating measurement and control unit

Version

Size: 160, 200, 250, 315, 400

Duct bend

Version

Variant: 45°, 90°

Size: 160, 200, 250, 315, 400

T-piece

Version

Size: 160, 200, 250, 315, 400

*) 1500, 3000 for 160, 200, 500 and 630

1500, 3000, 4500 for 250-400

Specification text

Swegon's type IBIS circular duct air diffuser with nozzles for suspended installation from a ceiling with the following functions:

- 100% flexible air distribution pattern
- Individually adjustable nozzles made of environmentally friendly plastic (polypropylene-PP)
- 1500 mm long modules
- Powder paint sprayed and baked white finish

Size: IBISb -315-3000-6 xx items

Accessory:

Duct section, 1,500 mm: IBIS Db -315 xx items